

FLOWX[®]



Valve
BUTTERFLY

ABOUT US

FLOWX - WORLD WIDE VALVE SUPPLIER AROUND YOU



FLOWX Valve is originated from Rome, Italy. Over the years, we have been focusing on valve development, production, sales and service.

Our product quality and good service have been widely praised!

Forge Ahead The Pursuit Of Excellence

B.S.ITALY

We are adhering to the modular design and service concept of FLOWX in Italy. We have formed more than ten series of butterfly valves, ball valves, pneumatic actuators, electric actuators and accessories in the Greater China region.

It provides the fluid control industry with the best choice in terms of its compatibility, economy and high performance.

FLOWX Valve (Shanghai) Co., Ltd. is a wholly owned subsidiary of the Chinese mainland. In recent years, the Flowx Group has increased its investment globally, effectively expanding its production and logistics capabilities to meet customer needs and the rapid development of the valve market.

The company's factory is located in Shanghai and covers an area of 35,000 square meters. It is currently the world's largest production base of Flowx company, with sales offices in Beijing, Shandong, Guangdong, Henan, Shijiazhuang, Tianjin and Chengdu.

**We believe that 7 factors to decide whether a customer will order or not.
As followings:**

 Manufacturer Company Development Scale

 Product Quality Control And Testing

 Product Professionalism

 Due Date Of Delivery

 Customer Service

 Price Advantage

 Customized Cooperation

TABLE OF CONTENT

- **KEY TO BUTTERFLY VALVE FIGURE NUMBER SYSTEM** 1
- **SEAT MATERIALS** 2
- **FEARURES & BENEFITS** 4
- **BUTTERFLY VALVE**

- Wafer Butterfly Valve 5
- Full Fined Fluorine Butterfly Valve 8
- Flanged Butterfly Valve 11
- LT Lug Type Butterfly Valve 15
- Ventilation Butterfly Valve 18
- U Type Flanged Butterfly Valve 21
- Powder Butterfly Valve 25
- UPVC Plastic Butterfly Valve..... 28
- Hard Seal Trip Eccentric Butterfly Valve..... 31
- High Performance Butterfly Valve 34
- Fire Safety Butterfly Valve 37
- Sanitary Butterfly Valve 40
- Pneumatic /Electric Actuator 42
- Accessories 43
- **OPERATION MANUAL AND INSTRUCTIONS** 44
- **OPERATION CAUTION&NOTICE**..... 47

Butterfly Valve FP10

1 Body Type

- 0 Soft Seal Butterfly Valve
- 1 Hard Seal butterfly Valve
- 2 High Performance Butterfly Valve
- 3 Plastic Butterfly Valve
- 4 Powder Butterfly Valve
- 5 Sanitary Butterfly Valve
- 6 Ventilation Butterfly Valve

2 Operated Type

- 0 Pneumatic Actuator (Double acting)
- OS Pneumatic Actuator (Single acting)
- OE DA Pneumatic Actuator+Reducing Gear
- OES... SR Pneumatic Actuator+Reducing Gear
- 1 Handle Lever
- 2 Worm Gear
- 3 Electric Actuator AC220V
- 31 Electric Actuator AC380V
- 32 Electric Actuator DC24V
- 33 Electric Actuator AC24V

3 Place of Origin of Actuator

- S FLOWX B.S Shanghai
- T FLOWX B.S Taiwan
- H..... FLOWX B.S Korea
- I FLOWX B.S ITALY
- G..... FLOWX B.S GERMANY
- 0 Others

4 Function of Actuator

- 1 Normal Open
- 2 Normal Closed
- 3 ON-OFF Type
- 4 4-20ma Feedback Type
- 5 4-20ma Intelligent Regulated Type
- 6 ON-OFF (Explosive proof)
- 7 4-20ma Feedback Type
(Explosive proof)
- 8 4-20ma Intelligent Regulated Type
(Explosive proof)
- 0 Others

5 Connection Type

- 1 Wafer
- 2 Flanged
- 3 Threaded
- 4 Welded
- 5 Clamped
- 6 LUG (LT)
- 7 Weld&Thread Per Each Connect Type
- 8 Double True
- 9 Clamp Cover
- 0 Others

6 Seat Material

- 1 EPDM
- 2 NBR
- 3 PTFE
- 4 VITON
- 5 FPM
- 6 Wear-Resisting EPDM
- 7 SS304
- 8 Alloy Steel
- 9 Hard Alloy Steel
- 0 Others

7 Others

- A Galvanized DI
- B DI with Nylon
- C DI with F4
- D..... Aluminium Bronz
- E SS304
- F SS316
- G..... UPVC
- H..... CPVC
- I WCB
- 0 Others

8 Body Material

- 1 DI/CI
- 2 WCB
- 3 SS304
- 4 Aluminium Alloy
- 5 SS316
- 6 UPVC
- 7 PP
- 8 CPVC
- 0 Others

9 Pressure Rating

- 1 PN6
- 2 PN10
- 3 PN16
- 4 PN25
- 5 PN40
- 6 PN64
- 7 PN100
- 0 Others

* The key is a guide only ,it is not intended to imply that al combinations can or will be produced.

Visit our website to know more details:www.flowxcontrol.com

SEAT MATERIALS

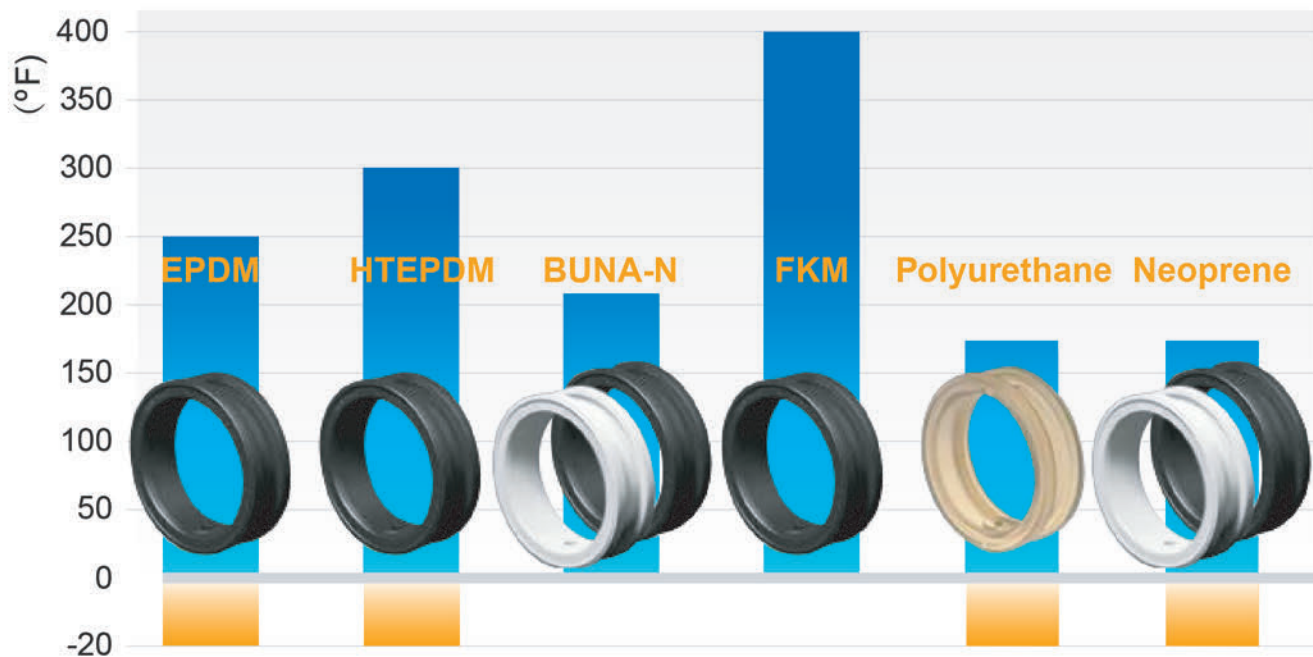

PEROXIDE CURED EPDM

-20°F to 250°F (-29°C to 121°C)

Flowx's peroxide cured EPDM (Ethylene Propylene Diene Monomer) seats have a higher resistance to abrasion, lower compression set, and higher temperature capabilities than sulfur cured seats. As a standard seat offering, Flowx's peroxide cured EPDM is the most universal and economical seat material used in our resilient seated butterfly valves. All of Flowx's peroxide cured EPDM seats are food grade and can be certified to NSF-61.

HTEPDM

-20°F to 300°F (-29°C to 150°C)

HTEPDM is a proprietary rubber blend offered by Flowx to increase the thermal resistance properties of standard EPDM and is formulated to provide long term service at elevated temperatures for hot water. HTEPDM Food Grade seats are suitable for sanitary applications as well as standard industrial uses.

BUNA-N (Black or White)

-20°F to 300°F (-29°C to 150°C)

BUNA-N is the commonly used name for Nitrile synthetic rubber. Nitrile is a copolymer of acrylonitrile and butadiene. BUNA-N is sometimes referred to as NBR, Nitrile, or Hycar. BUNA-N is a general purpose seat material particularly suitable for hydrocarbon service. BUNA-N is a standard Flowx seat material and food grade is available for sanitary applications.

FKM

0°F to 400°F (-18°C to 204°C)

FKM is the ASTM D1418 designation for Fluorinated Hydrocarbon Elastomers (Fluoroelastomers) such as Viton® (DuPont). FKM has some outstanding characteristics such as improved acid, oil, and temperature resistance over other seat materials.

POLYURETHANE

-20°F to 175°F (-29°C to 80°C)

Polyurethane seats are primarily used because of their resistance to abrasive wear. Polyurethane can be used in a reasonably broad range of services and will withstand severe impact, recover its original shape after distortion and resist abrasion better than other elastomers.

NEOPRENE SEAT (Black or White)

0°F to 180°F (-18°C to 82°C)

Neoprene is an all-purpose polymer with desirable characteristics including high resiliency with low compression, resistance to vegetable and animal oil, and flame resistance. This sealing material is excellent for refrigerants, ammonia and Freon, and is principally used in pulp and (non-bleached) paper lines. Neoprene is not recommended for strong oxidizing acids, chlorinated solvents, esters, ketones, aromatic hydrocarbons or hydraulic fluids. White neoprene is generally used in sanitary applications while the black grade provides better abrasion and oil resistance.

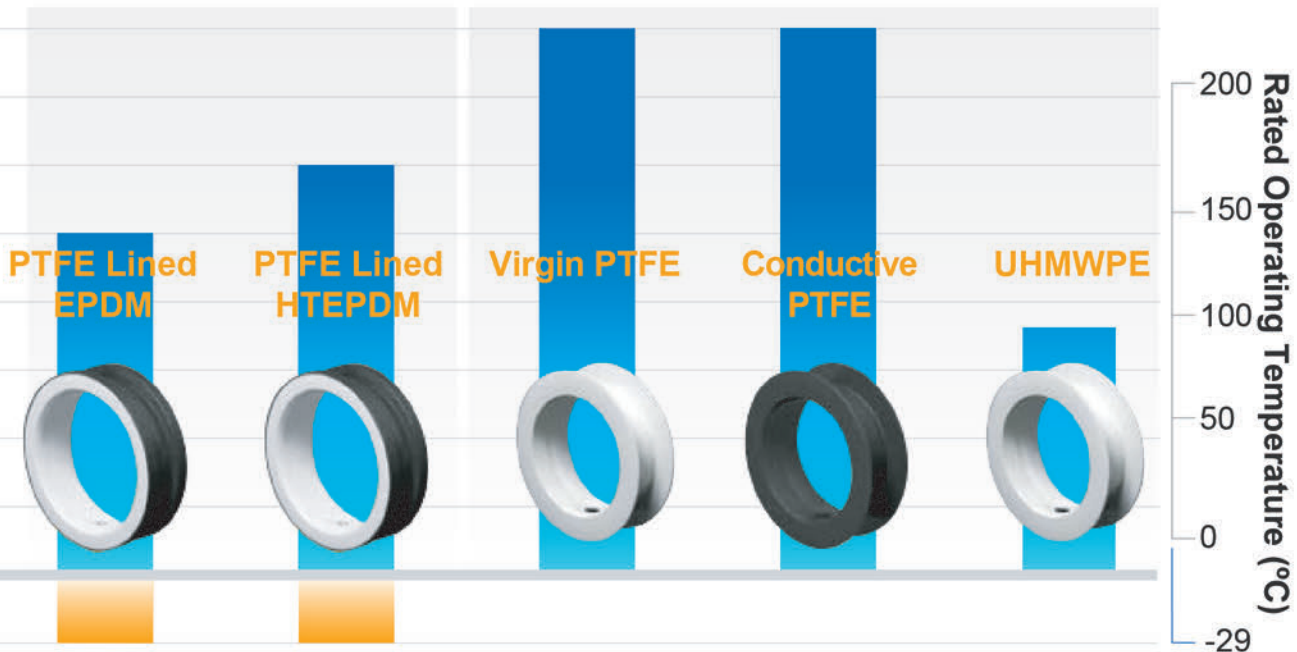

PTFE LINED EPDM

-20°F to 250°F (-29°C to 121°C)

PTFE lined EPDM seats consist of a PTFE liner which forms the flange sealing faces and the flow way of the seats which are molded on to EPDM elastomer backings. Only the inert, non-stick PTFE liner surface is exposed to the line media. The EPDM backing acts as a resilient support to the relatively rigid PTFE.

These seats are generally used in corrosive services.

PTFE LINED HTEPDM

-20°F to 300°F (-29°C to 150°C)

PTFE lined HTEPDM seats consist of a PTFE liner which forms the flange sealing faces and the flow way of the seats which are molded on to HTEPDM elastomer backings. HTEPDM is a proprietary rubber blend offered by Flowx to increase the thermal resistance properties of standard EPDM and is formulated to provide long term service at elevated temperatures.

VIRGIN PTFE

0°F to 400°F (-18°C to 204°C)

All Flowx PTFE seats and encapsulated discs are isostatically molded from pure, virgin PTFE material to meet Flowx's stringent material requirements. PTFE's inherent molecular bonding strength gives our seats an excellent chemical, high temperature, and tear resistance. Flowx's sintered PTFE offers low permeability properties to provide optimum protection against aggressive line medias.

Seat material availability depends on valve size and series. Please consult your local Flowx representative for your specific application as the pressure and temperature of service also affect seat life and performance.

CONDUCTIVE PTFE

0°F to 400°F (-18°C to 204°C)

Flowx's conductive PTFE seats and discs are available for installation in areas of the plant here explosion protection is important. This material was designed to prevent harmful electrostatic discharge. Flowx has combined electrostatic discharge protection and the excellent chemical resistance properties of PTFE. The seat and the disc have a minimum conductive PTFE thickness of 1/8" (3 mm) which provides optimum protection against permeation of the line media.

UHMWPE

0°F to 185°F (-18°C to 85°C)

UHMWPE seats and discs feature exceptional chemical resistance and are the ideal choice for highly abrasive chemical applications. The natural ability of the UHMWPE's high molecular weight to repel solids prevents in-line particles from damaging the valve's seat surfaces.

FEARURES & BENEFITS



ISOLATION FROM LINE MEDIA

Flowx's seat design and internal disc to stem connection isolates the line media from the body and stem.

INTERNAL DISC TO STEM CONNECTION

Sizes 2" – 20" (50mm–500mm)
 Flowx offers square and double "D" precision machined flats on the stem and in the disc. The Series 30/31 internal, non-wetted connections eliminate exposed external disc to stem connections. The disc and the stem connection minimizes hysteresis and produces maximum strength engagements. All stem designs incorporate a blowout proof feature.

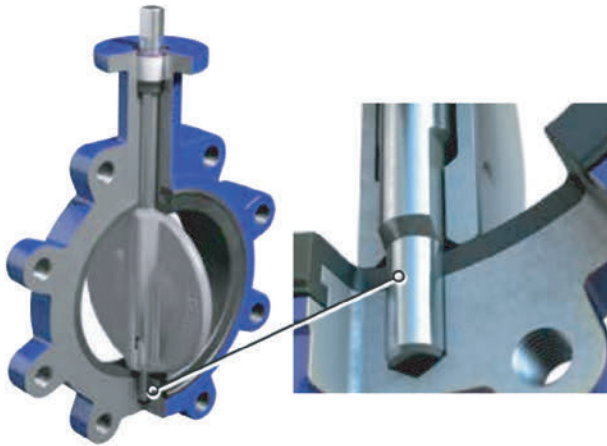

SEAT DESIGN

The seat is designed to seal with slip-on or weld-neck flanges and the molded o-ring eliminates the need for flange gaskets. The tongue and groove locks the seat in place and makes the valve dead end capable.



POLYESTER COATING

The Flowx standard polyester body coating is a hard, gloss red finish. The polyester coating provides excellent corrosion and wear resistance.



Chemical Resistant

Resistant to dilute acids and alkalis, petroleum solvents, alcohols, greases and oils.

Weatherability

Resistant to humidity, water and ultraviolet radiation.

Abrasion and Impact Resistant

SEACORR® COATING

This proprietary coating for actuators provides superior product protection in corrosive conditions, tested to ASTM B-117.



Other customer specified coating materials are available. Please consult your local Flowx representative for your specific application.

All Flowx valves are pressure tested to 110% of rated pressure to assure bubble tight shutoff.

Features

- Designed to MASS-SP67, API609 standards
- Flanged ends designed To PN16, PN10, DIN16, JIS10K, 16K, ANSI B16.1/16.5, BS4504, DIN2015.
- Working pressure: 225PSI TO 8" 150PSI To 12"
- Shell test : 350PSI, Seal Test: 250PSI
- Direct Mount ISO5211 for low profile, Cost-efficient operation
- Pneumatic actuator, electric actuator, worm gear, handle lever as operators.

Main Specification

Nominal Size	Operated Type	Work Pressure	Work Temperature	Seal Material	Disc Material	Body Material	Medium	Application	Connection Standard
DN25 ↓ 1200	Pneumatic Actuator	PN6	-15-85°C	EPDM	SS304/SS316	Ductile Iron	Water	Water Treatment	PN10/PN16
	Electric Actuator	PN10	-25-150°C	PTFE	Aluminum Bronze	SS304/SS316	Oil	Municipal Engineer	ANSI150
	Manual Hand Lever	PN16	-15-85°C	NBR	Nylon	WCB	Gas	Pharmacy	DIN16
	Worm Gear		-25-200°C	VITON	Ductile Iron 2205 2507 1.4529	Aluminium Alloy 2205 2507 1.4529	Powder FGDD	Auto Industry	JIS10K/16K

Manual Handle Lever Operated



- cavity filled TFE® seats to reduce the threat of media entrapment
- Block body and bolted end piece design for easy maintenance
- Polished clamp end to meet BS 4835.3

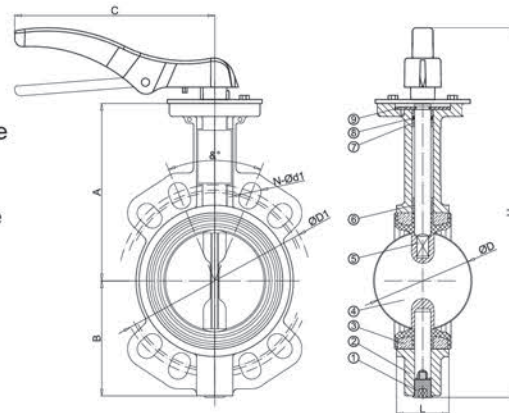

Dimensions

unit: mm

Size		CLASS150		JIS 10K		PN10		PN16		A	B	C	ΦD	H	L	WT (kg)
DN	NPS	D1	N-Φd1	D1	N-Φd1	D1	N-Φd1	D1	N-Φd1							
32	1¼"	88.9	4-Φ15.9	100	4-Φ19	100	4-Φ19	100	4-Φ19	110	64	213	34.6	242.35	33	1.2
40	1½"	98.5	4-Φ15.9	105	4-Φ19	110	4-Φ19	110	4-Φ19	120	70	213	43	258.35	33	1.8
50	2"	120.6	4-Φ19.1	120	4-Φ19	125	4-Φ19	125	4-Φ19	140	80	213	52.9	288.35	42	3.1
65	2½"	139.7	4-Φ19.1	140	4-Φ19	145	4-Φ19	145	4-Φ19	150	89	213	64.5	307.35	44.7	3.55
80	3"	152.4	8-Φ19.1	150	8-Φ19	160	8-Φ19	160	8-Φ19	158	95	213	78.8	321.35	46	3.95
100	4"	190.5	8-Φ19.1	175	8-Φ19	180	8-Φ19	180	8-Φ19	176	114	277	104	363.64	52	5.1
125	5"	215.9	4-Φ22.4	210	4-Φ23	210	4-Φ23	210	4-Φ19	190	127	277	123.3	390.64	54.4	7
150	6"	241.3	4-Φ22.4	240	4-Φ23	240	4-Φ23	240	4-Φ23	211	139	277	155.1	423.64	55.8	8.5

Visit our website to know more details: www.flowxcontrol.com

WAFER BUTTERFLY VALVE



Pneumatic Actuator Operated



PNEUMATIC ACTUATOR

- Rack and pinion design
- Spring return or double acting
- Open and closed adjustment stops
- True NAMUR accessory mounting
- Visual indicator

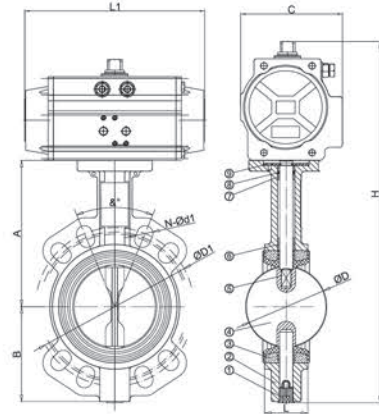

unit: mm

Dimensions

Size		CLASS150		JIS 10K		PN10		PN16		A	B	ΦD	L	DOUBLE ACTING			WT (kg)
DN	NPS	D1	N-Φd1	D1	N-Φd1	D1	N-Φd1	D1	N-Φd1					H	L1	C	
32	1 1/4"	88.9	4-Φ15.9	100	4-Φ19	100	4-Φ19	100	4-Φ19	110	64	34.6	33	263.5	139.5	71	1.4
40	1 1/2"	98.5	4-Φ15.9	105	4-Φ19	110	4-Φ19	110	4-Φ19	120	70	43	33	279.5	139.5	71	2.6
50	2"	120.6	4-Φ19.1	120	4-Φ19	125	4-Φ19	125	4-Φ19	140	80	52.9	42	309.5	139.5	71	3.9
65	2 1/2"	139.7	4-Φ19.1	140	4-Φ19	145	4-Φ19	145	4-Φ19	150	89	64.5	45	339.5	162	80.5	4.9
80	3"	152.4	8-Φ19.1	150	8-Φ19	160	8-Φ19	160	8-Φ19	158	95	78.8	46	353.5	162	80.5	5.3
100	4"	190.5	8-Φ19.1	175	8-Φ19	180	8-Φ19	180	8-Φ19	176	114	104	52	407	207	95	7.4
125	5"	215.9	4-Φ22.4	210	4-Φ23	210	4-Φ23	210	4-Φ19	190	127	123.3	55	445.5	237.5	106	10.2
150	6"	241.3	4-Φ22.4	240	4-Φ23	240	4-Φ23	240	4-Φ23	211	139	155.1	56	491.5	271.5	123	13.5
200	8"	298.5	4-Φ22.4	290	4-Φ23	295	4-Φ23	295	4-Φ23	235	175	202.5	61	586.5	328	137	20.5
250	10"	316.9	4-Φ25.4	355	4-Φ25	350	4-Φ23	355	4-Φ28	265	203	250.5	66	651.5	366	148	29.2

Electric Actuator Operated



ELECTRIC ACTUATOR

- AC 24V, 220V, 230V, 380V
DC 12V, 24V
- NEMA 4 and NEMA 7 enclosures
- Manual override
- visual indicator

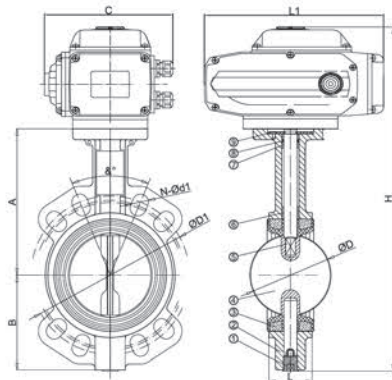

unit: mm

Dimensions

Size		CLASS150		JIS 10K		PN10		PN16		A	B	ΦD	L	H	L1	C	WT (kg)
DN	NPS	D1	N-Φd1	D1	N-Φd1	D1	N-Φd1	D1	N-Φd1								
32	1 1/4"	88.9	4-Φ15.9	100	4-Φ19	100	4-Φ19	100	4-Φ19	110	64	34.6	33	311.5	165	140.5	2.9
40	1 1/2"	98.5	4-Φ15.9	105	4-Φ19	110	4-Φ19	110	4-Φ19	120	70	43	33	327.5	165	140.5	3.3
50	2"	120.6	4-Φ19.1	120	4-Φ19	125	4-Φ19	125	4-Φ19	140	80	52.9	42	357.5	165	140.5	4.6
65	2 1/2"	139.7	4-Φ19.1	140	4-Φ19	145	4-Φ19	145	4-Φ19	150	89	64.5	45	376.5	165	140.5	5.1
80	3"	152.4	8-Φ19.1	150	8-Φ19	160	8-Φ19	160	8-Φ19	158	95	78.8	46	390.5	211.5	140.5	5.5
100	4"	190.5	8-Φ19.1	175	8-Φ19	180	8-Φ19	180	8-Φ19	176	114	104	52	458.5	211.5	154	8.4
125	5"	215.9	4-Φ22.4	210	4-Φ23	210	4-Φ23	210	4-Φ19	190	127	123.3	55	485.5	259	154	10.3
150	6"	241.3	4-Φ22.4	240	4-Φ23	240	4-Φ23	240	4-Φ23	211	139	155.1	56	553	259	186	15
200	8"	298.5	4-Φ22.4	290	4-Φ23	295	4-Φ23	295	4-Φ23	235	175	202.5	61	613	259	186	19
250	10"	316.9	4-Φ25.4	355	4-Φ25	350	4-Φ23	355	4-Φ28	265	203	250.5	66	671	283.5	186	26.7

Technical Material List

APPLICABLE STANDARDS & TECHNICAL NOTES:							
DESIGN CODE	API609			END STANDARD	ANSI 150#/JIS 10K		
INSPECTION&TEST	API508			FACE TO FACE	API609		
NO.	PARTS NAME	MATERIAL	QTY	NO.	PARTS NAME	MATERIAL	QTY
1	TOP SILK	CARBON STEEL	1	6	LONG BUSHING	PTFE	1
2	BODY	DI/WCB/CF8/CF8M	1	7	SHORT BUSHING	PTFE	1
3	SEAT	EPDM	1	8	O-RING	NBR	2
4	DISC	WCB/DI+NYLON/CF8/CF8M	1	9	THRUST INSERT	CARBON STEEL	1
5	STEM	SS416	2				
TEST PRESSURE							
		SHELL		SEAL			
	HYDROSTATIC	24/15 kg/cm ²		17.6/11 kg/cm ²			
	AIR	—		—			
TITLE: WAFER BUTTERFLY VALVE							
SIZE	DN32-DN250			DWG NO.	FT0114000003-1.1		



8 – STEM: Precision square disc to stem connection drives the disc without the need for screws or pins. The close tolerance, square connection that drives the valve disc is an exclusive feature of the Flowx valve. Disassembly of the Flowx stem is just a matter of pulling the stem out of the disc.

1 – STEM RETAINING ASSEMBLY: The stem is retained in the body by means of a unique stainless steel Spirolox® retaining ring, a thrust washer and two C-rings, manufactured from brass as standard, stainless steel upon request.

2 – STEM BUSHING: Non-corrosive, heavy duty acetal bushing absorbs actuator side thrust.

3 – STEM SEAL: Double “U” cup seal design is self-adjusting and gives positive sealing in both directions.

4 – PRIMARY AND SECONDARY SEALS: These seals prevent line media from coming in contact with the stem or body. The primary seal is an interference fit of the molded seat flat with the disc hub. The secondary seal is created because the stem diameter is greater than the diameter of the seat stem hole.

5 – BODY: One piece wafer or lug style. Polyester coating for excellent corrosion resistance. Nylon 11 coating is available as an option.

6 – SEAT: Flowx’s tongue and groove seat design provides complete isolation of flowing media from the body. The seat also features a molded o-ring which eliminates the use of flange gaskets.

7 – DISC: Casting is spherically machined and hand polished to provide a bubble tight shutoff, minimum torque, and longer seat life. Flowx’s resilient Nylon 11 coating comes as standard.

Product Description

- The lining butterfly valve body is a split type combination. Easy to assemble and seal adjustment, when the valve is working, only the fluoroplastic seat and the fluoroplastic valve plate are in contact with the medium.
- The inner surface of the valve body channel is smooth, the fluid resistance is small, the CV value is high, the circulation capacity is strong, the torque is moderate, and the zero leakage of the medium is completely achieved. The valve is small in size, light in weight, compact in structure, rapid in switching, beautiful in appearance, and excellent in craftsmanship. Reliable performance, light operation, long service life.
- The valve can withstand any corrosive media other than molten alkali metals and elements. It is a gas, liquid, semi-fluid pipeline and container for chemical, petroleum, pharmaceutical, food, steel smelting, papermaking, hydropower, and environmental protection systems. Do a quick cut-off and adjust the best product for your device.
- Lining materials: PTFE, FEP, PFA, GXPO, etc.
- Connection form: clip type, flange type, lug type connection
- Drive mode: manual, turbine, electric, pneumatic

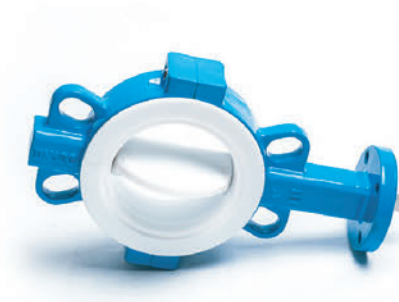

Main specification

Nominal Size	Operated Type	Work Pressure	Work Temperature	Seal Material	Disc Material	Body Material	Medium	Application	Connection Standard
DN25	Pneumatic Actuator	PN1.0	-15-150°C	PTFE	WCB	Ductile Iron	Strong Acid	Lithium Battery	PN10/PN16
↓ 300	Electric Actuator	PN1.6		FEP	SS304	WCB	Strong Alkali	Desalination	ANSI150
	Manual Hand Lever			PFA		Stainless Steel	Strong Oxidant	Coal Chemical	DIN16
	Worm Gear			GXPO				Chemical Industry Rubber Papermarking Pharmacy	JIS10K/16K

Connection Type Wafer Type, Flanged Type, Lug Type, ect.

Visit our website to know more details: www.flowxcontrol.com

Manual Handle Lever Operated

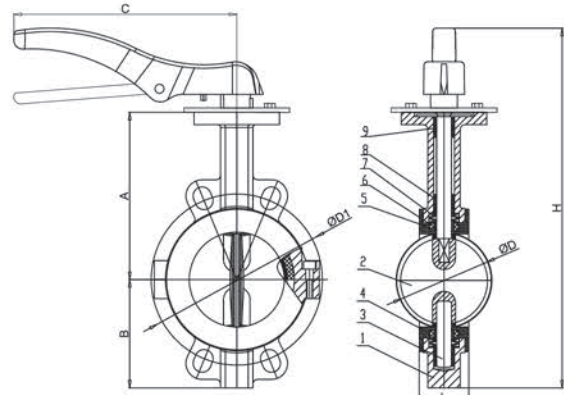

unit: mm

Dimensions

Size		CLASS150		JIS 10K		PN10		PN16		A	B	L	ΦD	H	C	WT (kg)
DN	NPS	D1	N-Φd1	D1	N-Φd1	D1	N-Φd1	D1	N-Φd1							
50	2"	120.6	2-Φ19.1	120	2-Φ19	125	2-Φ19	125	2-Φ19	140	80	43	53	288	213	-
65	2½"	139.7	2-Φ19.1	140	2-Φ19	145	2-Φ19	145	2-Φ19	150	89	45	63	307	213	-
80	3"	152.4	2-Φ19.1	150	2-Φ19	160	2-Φ19	160	2-Φ19	158	95	45	79	321	213	-
100	4"	190.5	2-Φ19.1	175	4-Φ19	180	2-Φ19	180	4-Φ19	176	114	52	104	379	277	-
125	5"	215.9	4-Φ22.4	210	4-Φ23	210	2-Φ23	210	4-Φ19	190	125	56	123.3	406	277	-
150	6"	241.3	4-Φ22.4	240	4-Φ23	240	4-Φ23	240	4-Φ23	210	139	56	155.1	438	277	-

Worm Gear Operated

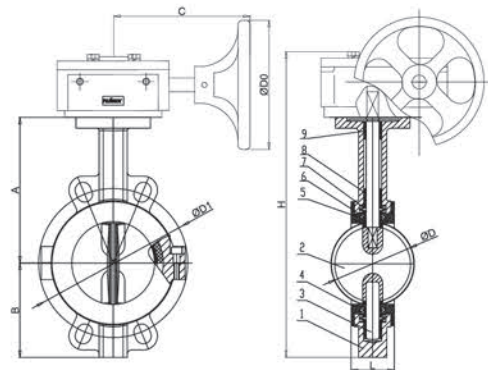

unit: mm

Dimensions

Size		CLASS150		JIS 10K		PN10		PN16		A	B	L	ΦD	H	C	WT (kg)
DN	NPS	D1	N-Φd1	D1	N-Φd1	D1	N-Φd1	D1	N-Φd1							
50	2"	120.6	2-Φ19.1	120	2-Φ19	125	2-Φ19	125	2-Φ19	140	80	43	53	268	120	-
65	2½"	139.7	2-Φ19.1	140	2-Φ19	145	2-Φ19	145	2-Φ19	150	89	45	63	287	120	-
80	3"	152.4	2-Φ19.1	150	2-Φ19	160	2-Φ19	160	2-Φ19	158	95	45	79	301	120	-
100	4"	190.5	2-Φ19.1	175	4-Φ19	180	2-Φ19	180	4-Φ19	176	114	52	104	338	120	-
125	5"	215.9	4-Φ22.4	210	4-Φ23	210	2-Φ23	210	4-Φ23	190	125	56	123.3	365	120	-
150	6"	241.3	4-Φ22.4	240	4-Φ23	240	4-Φ23	240	4-Φ23	210	139	56	155.1	297	120	-
200	8"	298.5	4-Φ22.4	290	4-Φ23	295	4-Φ23	295	4-Φ23	236	175	60	202.5	467	200	-
250	10"	361.9	4-Φ25.4	355	4-Φ25	350	4-Φ23	355	4-Φ28	275	203	68	250.5	534	200	-
300	12"	431.8	4-Φ25.4	400	4-Φ25	400	4-Φ23	410	4-Φ28	305	242	78	301.5	618	300	-
350	14"	476	4-Φ28.5	445	4-Φ25	460	4-Φ23	470	4-Φ28	337	284	78	333.1	692	300	-

FULLY LINED BUTTERFLY VALVE



Pneumatic Actuator Operated

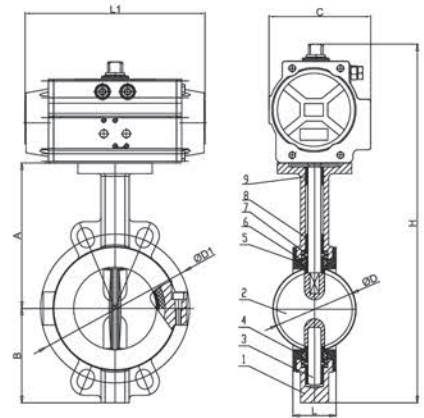

unit: mm

Dimensions

Size		CLASS150		JIS 10K		PN10		PN16		A	B	L	ΦD	H	L1	C	WT (kg)
DN	NPS	D1	N-Φd1	D1	N-Φd1	D1	N-Φd1	D1	N-Φd1								
50	2"	120.6	2-Φ19.1	120	2-Φ19	125	2-Φ19	125	2-Φ19	140	80	43	53	320.5	162	80.5	-
65	2½"	139.7	2-Φ19.1	140	2-Φ19	145	2-Φ19	145	2-Φ19	150	89	45	65	356	207	95	-
80	3"	152.4	2-Φ19.1	150	2-Φ19	160	2-Φ19	160	2-Φ19	158	95	45	79	370	207	95	-
100	4"	190.5	2-Φ19.1	175	4-Φ19	180	2-Φ19	180	4-Φ19	176	114	52	104	418.5	237.5	106	-
125	5"	215.9	4-Φ22.4	210	4-Φ23	210	2-Φ23	210	4-Φ23	190	125	56	123.3	458.5	271.5	123	-
150	6"	241.3	4-Φ22.4	240	4-Φ23	240	4-Φ23	240	4-Φ23	210	139	56	155.1	520.5	328	137	-
200	8"	298.5	4-Φ22.4	290	4-Φ23	295	4-Φ23	295	4-Φ23	236	175	60	202.5	594.5	366	148	-
250	10"	361.9	4-Φ25.4	355	4-Φ25	350	4-Φ23	355	4-Φ28	275	203	68	250.5	684	428	164	-
300	12"	431.8	4-Φ25.4	400	4-Φ25	400	4-Φ23	410	4-Φ28	305	242	78	301.5	769	430	186.5	-
350	14"	476	4-Φ28.5	445	4-Φ25	460	4-Φ23	470	4-Φ28	337	284	78	333.1	873	482	204	-

Electric Actuator Operated

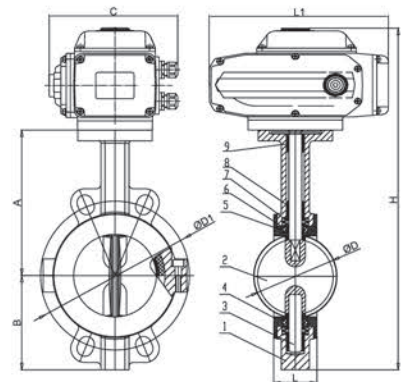

unit: mm

Dimensions

Size		CLASS150		JIS 10K		PN10		PN16		A	B	L	ΦD	H	L1	C	WT (kg)
DN	NPS	D1	N-Φd1	D1	N-Φd1	D1	N-Φd1	D1	N-Φd1								
50	2"	120.6	2-Φ19.1	120	2-Φ19	125	2-Φ19	125	2-Φ19	140	80	43	53	357.5	162	140.5	-
65	2½"	139.7	2-Φ19.1	140	2-Φ19	145	2-Φ19	145	2-Φ19	150	89	45	65	407.5	211.5	154	-
80	3"	152.4	2-Φ19.1	150	2-Φ19	160	2-Φ19	160	2-Φ19	158	95	45	79	421.5	211.5	154	-
100	4"	190.5	2-Φ19.1	175	4-Φ19	180	2-Φ19	180	4-Φ19	176	114	52	104	493	259	186	-
125	5"	215.9	4-Φ22.4	210	4-Φ23	210	2-Φ23	210	4-Φ23	190	127	56	123.3	520	259	186	-
150	6"	241.3	4-Φ22.4	240	4-Φ23	240	4-Φ23	240	4-Φ23	210	139	56	155.1	552	259	186	-
200	8"	298.5	4-Φ22.4	290	4-Φ23	295	4-Φ23	295	4-Φ23	236	175	60	202.5	614	259	186	-
250	10"	361.9	4-Φ25.4	355	4-Φ25	350	4-Φ23	355	4-Φ28	275	203	68	250.5	684	259	186	-
300	12"	431.8	4-Φ25.4	400	4-Φ25	400	4-Φ23	410	4-Φ28	305	242	78	301.5	776.5	283.5	193	-
350	14"	476	4-Φ28.5	445	4-Φ25	460	4-Φ23	470	4-Φ28	337	284	78	333.1	850.5	283.5	193	-

Features

- Small and lightweight, easy to disassemble and repair, and can be installed in any position.
- The structure is simple and compact, the operating torque is small, and the rotation of 90° turns on quickly.
- The flow characteristics of the linear trend, good regulation performance.
- The connection between the butterfly plate and the valve stem adopts a non-pin structure to overcome possible internal leakage points.
- The spherical shape of the outer circle of the butterfly plate improves the sealing performance and prolongs the service life of the valve. The zero leakage is still maintained when the pressure is switched on and off more than 50,000 times.
- The seal can be replaced, and the seal is reliable to achieve two-way seal.
- The butterfly board can be sprayed with layers according to user requirements, such as nylon or polytetrafluoroethylene.
- Flange butterfly valve is suitable for temperature $\leq 120\text{ }^{\circ}\text{C}$ or $\leq 150\text{ }^{\circ}\text{C}$, nominal pressure $\leq 1.6\text{MPa}$ water supply and drainage, sewage, food, heating, gas, shipbuilding, hydropower, metallurgy, energy systems and textile and other industries, especially for two-way sealing and Easy to corrode valve body, adjust flow and shutoff medium.



Main Specification

Nominal Size	Operated Type	Work Pressure	Work Temperature	Seal Material	Disc Material	Body Material	Medium	Application	Connection Standard
DN25	Pneumatic Actuator	PN6	-15-85°C	EPDM	SS304/SS316	Ductile Iron	Water	Water Treatment	PN10/PN16
	Electric Actuator	PN10	-25-150°C	PTFE	Aluminum Bronze	SS304/SS316	Oil	Municipal Engineer	ANSI150
	Manual Hand Lever	PN16	-15-85°C	NBR	Nylon	WCB	Gas	Pharmacy	DIN16
1200	Worm Gear		-25-200°C	VITON	Ductile Iron	Aluminium Alloy	Powder FGDD	Auto Industry	JIS10K/16K
					2205	2205			
					2507	2507			
					1.4529	1.4529			

Visit our website to know more details: www.flowxcontrol.com

FLANGED BUTTERFLY VALVE



Manual Handle Lever Operated

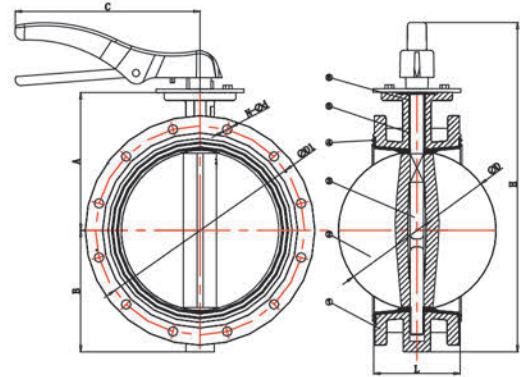

Dimensions

unit: mm

Size		CLASS150		JIS 10K		PN10		PN16		A	B	L	ΦD	H	C	WT (kg)
DN	NPS	D1	N-Φd1	D1	N-Φd1	D1	N-Φd1	D1	N-Φd1							
50	2"	120.6	4-Φ19.1	120	4-Φ19	125	4-Φ19	125	4-Φ19	118	75	108	52.9	261	213	6.8
65	2½"	139.7	4-Φ19.1	140	4-Φ19	145	4-Φ19	145	4-Φ19	130	93	112	64.5	291	213	9.6
80	3"	152.4	4-Φ19.1	150	8-Φ19	160	8-Φ19	160	8-Φ19	145	100	114	78.8	313	213	10
100	4"	190.5	8-Φ19.1	175	8-Φ19	180	8-Φ19	180	8-Φ19	155	114	127	104	342	277	12.2
125	5"	215.9	8-Φ22.5	210	8-Φ23	210	8-Φ19	210	8-Φ23	170	125	140	123.3	368	277	17.1
150	6"	241.3	8-Φ22.5	240	8-Φ23	240	8-Φ23	240	8-Φ23	190	143	140	155.1	406	277	29.4
200	8"	298.5	8-Φ22.5	290	12-Φ23	295	8-Φ23	295	12-Φ23	205	170	152	202.5	448	277	27.9

Worm Gear Operated

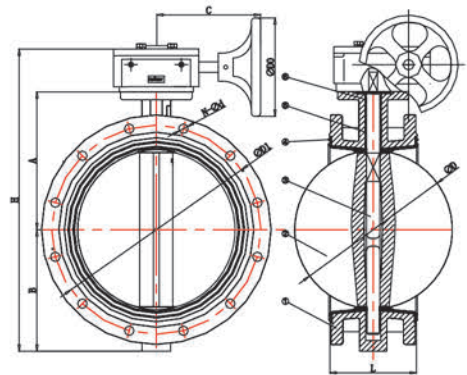

Dimensions

unit: mm

Size		CLASS150		JIS 10K		PN10		PN16		A	B	L	ΦD	H	C	ΦD0	WT (kg)
DN	NPS	D1	N-Φd1	D1	N-Φd1	D1	N-Φd1	D1	N-Φd1								
50	2"	120.6	4-Φ19.1	120	4-Φ19	125	4-Φ19	125	4-Φ19	118	75	108	52.9	241	99	120	7.2
65	2½"	139.7	4-Φ19.1	140	4-Φ19	145	4-Φ19	145	4-Φ19	130	93	112	64.5	271	99	120	10
80	3"	152.4	4-Φ19.1	150	8-Φ19	160	8-Φ19	160	8-Φ19	145	100	114	78.8	293	99	120	10.4
100	4"	190.5	8-Φ19.1	175	8-Φ19	180	8-Φ19	180	8-Φ19	155	114	127	104	317	99	120	12.6
125	5"	215.9	8-Φ22.5	210	8-Φ23	210	8-Φ23	210	8-Φ23	170	125	140	123.3	349	115	200	18.3
150	6"	241.3	8-Φ22.5	240	8-Φ23	240	8-Φ23	240	8-Φ23	190	143	140	155.1	387	115	200	20.6
200	8"	298.5	8-Φ22.5	290	12-Φ23	295	8-Φ23	295	12-Φ23	205	170	152	202.5	446	220	300	32.6
250	10"	361.9	12-Φ25.5	355	12-Φ25	350	12-Φ23	355	12-Φ28	235	198	165	250.5	504	220	300	46.1
300	12"	431.8	12-Φ25.5	400	16-Φ25	400	12-Φ23	410	12-Φ28	280	223	178	301.5	574	220	300	61.4

Pneumatic Actuator Operated

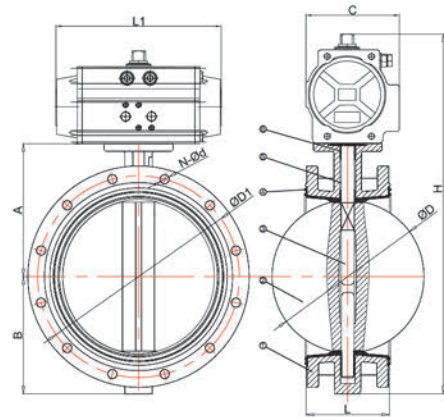

Dimensions

unit: mm

Size		CLASS150		JIS 10K		PN10		PN16		A	B	L	ΦD	H	L1	C	WT (kg)
DN	NPS	D1	N-Φd1	D1	N-Φd1	D1	N-Φd1	D1	N-Φd1								
50	2"	120.6	4-Φ19.1	120	4-Φ19	125	4-Φ19	125	4-Φ19	118	75	108	52.9	282.5	139.5	71	6.9
65	2½"	139.7	4-Φ19.1	140	4-Φ19	145	4-Φ19	145	4-Φ19	130	93	112	64.5	323.5	162	80.5	11.2
80	3"	152.4	4-Φ19.1	150	8-Φ19	160	8-Φ19	160	8-Φ19	145	100	114	78.8	345.5	162	80.5	11.6
100	4"	190.5	8-Φ19.1	175	8-Φ19	180	8-Φ19	180	8-Φ19	155	114	127	104	386	207	95	14.8
125	5"	215.9	8-Φ22.5	210	8-Φ23	210	8-Φ23	210	8-Φ19	170	125	140	123.3	423.5	237.5	106	20.6
150	6"	241.3	8-Φ22.5	240	8-Φ23	240	8-Φ23	240	8-Φ23	190	143	140	155.1	474.5	271.5	123	24.5
200	8"	298.5	8-Φ22.5	290	12-Φ23	295	8-Φ23	295	12-Φ23	205	170	152	202.5	546.5	328	137	36
250	10"	361.9	12-Φ25.5	355	12-Φ25	350	12-Φ23	355	12-Φ28	235	198	165	250.5	616.5	366	148	51.3
300	12"	540.0	12-Φ25.5	400	16-Φ25	400	12-Φ23	410	12-Φ28	280	223	178	301.5	709	428	164	71.8
350	14"	578.0	12-Φ28.5	455	16-Φ25	460	16-Φ23	470	16-Φ28	328	250	190	333.3	800	430	186.5	102

Electric Actuator Operated

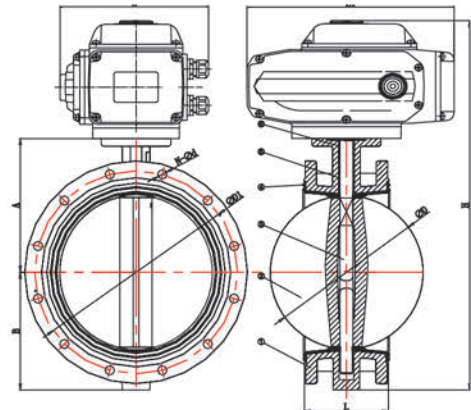

Dimensions

unit: mm

Size		CLASS150		JIS 10K		PN10		PN16		A	B	L	ΦD	H	L1	C	WT (kg)
DN	NPS	D1	N-Φd1	D1	N-Φd1	D1	N-Φd1	D1	N-Φd1								
50	2"	120.6	4-Φ19.1	120	4-Φ19	125	4-Φ19	125	4-Φ19	118	75	108	52.9	330.5	165	140.5	8.3
65	2½"	139.7	4-Φ19.1	140	4-Φ19	145	4-Φ19	145	4-Φ19	130	93	112	64.5	360.5	165	140.5	11.1
80	3"	152.4	4-Φ19.1	150	8-Φ19	160	8-Φ19	160	8-Φ19	145	100	114	78.8	382.5	165	140.5	11.5
100	4"	190.5	8-Φ19.1	175	8-Φ19	180	8-Φ19	180	8-Φ19	155	114	127	104	437.5	211.5	154	15.5
125	5"	215.9	8-Φ22.5	210	8-Φ23	210	8-Φ23	210	8-Φ19	170	125	140	123.3	463.5	211.5	154	20.4
150	6"	241.3	8-Φ22.5	240	8-Φ23	240	8-Φ23	240	8-Φ23	190	143	140	155.1	536	259	186	25.7
200	8"	298.5	8-Φ22.5	290	12-Φ23	295	8-Φ23	295	12-Φ23	205	170	152	202.5	578	259	186	34.5
250	10"	361.8	12-Φ25.5	355	12-Φ25	350	12-Φ23	355	12-Φ28	235	198	165	250.5	636	259	186	48.5
300	12"	431.8	12-Φ25.5	400	16-Φ25	400	12-Φ23	410	12-Φ28	280	223	178	301.5	732.5	283.5	193	67.3
350	14"	476.5	12-Φ28.5	445	16-Φ25	460	16-Φ23	470	16-Φ28	328	250	190	333.3	807.5	283.5	193	94.5

Technical Material List

APPLICABLE STANDARDS & TECHNICAL NOTES:							
DESIGN CODE		API609		END STANDARD		ANSI 150#/JIS 10K	
INSPECTION&TEST		API598		FACE TO FACE		API609	
NO.	PARTS NAME	MATERIAL	QTY	NO.	PARTS NAEM	MATERIAL	QTY
1	BODY	DI/WCB/CF8/CF8M	1	4	SEAT	NBR/EPDM/VITON	1
2	DISC	WCB/DI+NYLON/CF8/CF8M	1	5	BUSHING	PTFE	4
3	SHAFT	SS410	1	6	O-RING	NBR	1
TEST PRESSURE							
		SHELL		SEAL			
HYDROSTATIC		24/15 kg/cm ²		17.6/11 kg/cm ²			
AIR		—		—			
TITLE: PNEUMATIC FLANGE BUTTERFLY VALVE							
SIZE		DN50-DN250		DWG NO.		FT01140000002-1	

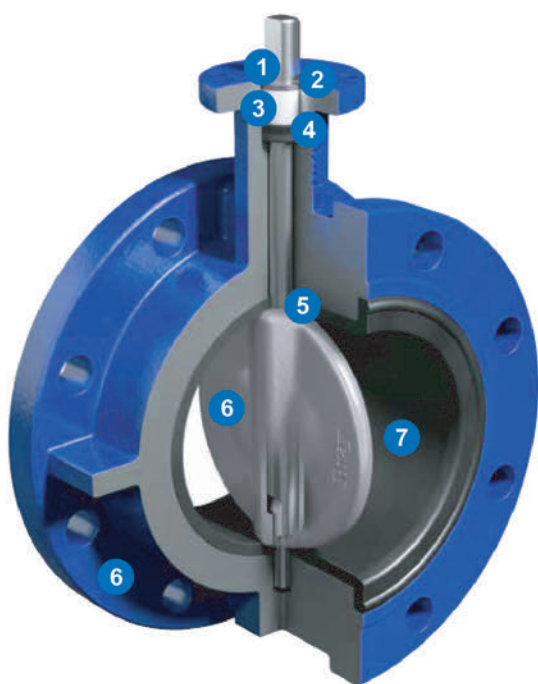

1 – STEM: Precision square and double "D" disc to stem connection drives the disc without the need for screws or pins. The close tolerance, square and double "D" connection that drives the valve disc is an exclusive feature of the Flowx valve. Disassembly of the Flowx stem is just a matter of pulling the stem out of the disc.

2 – STEM RETAINING ASSEMBLY: The stem is retained in the body by means of a unique stainless steel Spirolox® retaining ring, a thrust washer and two C-rings, manufactured from brass as standard, stainless steel upon request.

3 – STEM BUSHING: Non-corrosive, heavy duty acetal bushing absorbs actuator side thrusts.

4 – STEM SEAL: Double "U" cup seal design is self-adjusting, gives positive sealing in both directions, and prevents external substances from entering the stem bore.

5 – PRIMARY AND SECONDARY SEALS: These seals prevent line media from coming in contact with the stem or body. The primary seal is an interference fit of the molded seat flat with the disc hub. The secondary seal is created because the stem diameter is greater than the diameter of the seat stem hole.

6 – DISC: Casting is spherically machined and hand polished to provide a bubble tight shutoff, minimum torque, and longer seat life. Flowx's resilient Nylon 11 coating comes as standard.

7 – SEAT: Flowx's bonded seat offers lower torque and provides complete isolation of flowing media from the body. The seat also features a molded O-ring which eliminates the use of flange gaskets.

Product Description

- LT type is also called single Plate butterfly valve, lug type butterfly valve
- It is a simple structure of the regulating valve. that can be used for low pressure pipeline medium switching means that the closing element (valve or butterfly plate) is a disk, and rotates around the valve shaft to open and close.
- A valve that can be used to control the flow of various types of fluids such as air, water, steam, various corrosive media, mud, oil products, liquid metals. In the pipeline mainly cut off and throttling effect. Butterfly valve opening and closing device is a disc-shaped butterfly plate, rotating around its own axis in the valve body, so as to achieve the purpose of opening and closing or adjusting.

Main Specification

Nominal Size	Operated Type	Work Pressure	Work Temperature	Seal Material	Disc Material	Body Material	Medium	Application	Connection Standard
DN50	Pneumatic Actuator	PN25	-15-85°C	EPDM	SS304/SS316	Ductile Iron	Water	Water Treatment	PN10/PN16
	Electric Actuator		-25-150°C	PTFE	Nylon	SS304/SS316	Oil	Municiple Engineer	ANSI150
1200	Manual Hand Lever	Worm Gear	-15-85°C	NBR	Ductile Iron	WCB	Gas	Pharmacy	DIN16
			-25-200°C	VITON	2205 2507 1.4529	Aluminium Alloy 2205/2507 1.4529	Powder FGDD	Auto Industry	JIS10K/16K

Manual Handle Lever Operated

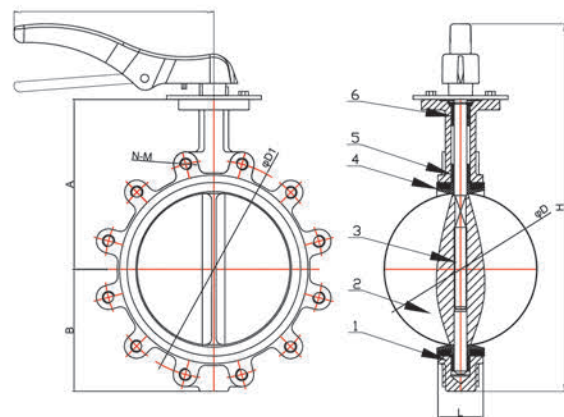

unit: mm

Dimensions

Size		CLASS150		JIS 10K		PN10		PN16		A	B	L	ΦD	H	C	WT (kg)
DN	NPS	D1	N-M	D1	N-M	D1	N-M	D1	N-M							
50	2"	120.6	4-5/8	125	4-M16	125	4-M16	125	4-M16	140	80	42	53	288	213	-
65	2½"	139.7	4-5/8	145	4-M16	145	4-M16	145	4-M16	150	89	44.7	65	307	213	-
80	3"	152.4	4-5/8	160	8-M16	160	8-M16	160	8-M16	158	95	46	79	321	213	-
100	4"	190.5	8-5/8	180	8-M16	180	8-M16	180	8-M16	175	114	52	104	378	277	-
125	5"	215.9	8-3/4	210	8-M16	210	8-M16	210	8-M16	190	127	54.4	123.3	406	277	-
150	6"	241.3	8-3/4	240	8-M20	240	8-M20	240	8-M20	211	139	55.8	155.1	439	277	-
200	8"	298.5	8-3/4	295	12-M20	295	12-M20	295	12-M20	235	175	60.6	202.5	-	-	-
250	10"	361.9	12-7/8	350	12-M20	350	12-M24	355	12-M24	265	203	65.5	250.5	-	-	-
300	12"	431.8	12-7/8	400	16-M20	400	16-M24	410	16-M24	305	242	76.9	301.5	-	-	-

Visit our website to know more details: www.flowxcontrol.com

LT LUG TYPE BUTTERFLY VALVE



Pneumatic Actuator Operated

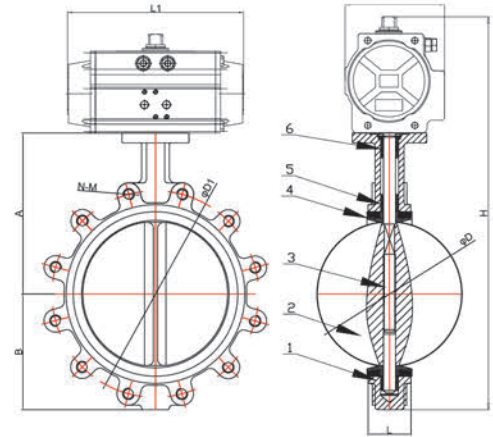

unit: mm

Dimensions

Size		CLASS150		PN10		PN16		A	B	L	ΦD	H	C	L1	WT (kg)
DN	NPS	D1	N-M	D1	N-M	D1	N-M								
50	2"	120.6	4-5/8	125	4-M16	125	4-M16	140	80	42	53	309.5	71	139.5	-
65	2½"	139.7	4-5/8	145	4-M16	145	4-M16	150	89	44.7	65	339.5	80.5	162	-
80	3"	152.4	4-5/8	160	8-M16	160	8-M16	158	95	46	79	353.5	80.5	162	-
100	4"	190.5	8-5/8	180	8-M16	180	8-M16	175	114	52	104	406	95	207	-
125	5"	215.9	8-3/4	210	8-M16	210	8-M16	190	127	54.4	123.3	445.5	106	237.5	-
150	6"	241.3	8-3/4	240	8-M20	240	8-M20	211	139	55.8	155.1	491.5	123	271.5	-
200	8"	298.5	8-3/4	295	12-M20	295	12-M20	235	175	60.6	202.5	581.5	137	328	-
250	10"	361.9	12-7/8	350	12-M20	355	12-M24	265	203	65.5	250.5	651.5	164	366	-
300	12"	431.8	12-7/8	400	16-M20	410	16-M24	305	242	76.9	301.5	753	186.5	428	-

Electric Actuator Operated

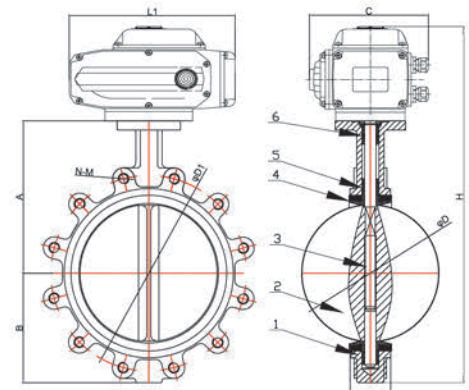

unit: mm

Dimensions

Size		CLASS150		PN10		PN16		A	B	L	ΦD	H	C	L1	WT (kg)
DN	NPS	D1	N-M	D1	N-M	D1	N-M								
50	2"	120.6	4-5/8	125	4-M16	125	4-M16	140	80	42	53	357	140.5	165	-
65	2½"	139.7	4-5/8	145	4-M16	145	4-M16	150	89	44.7	65	376	140.5	165	-
80	3"	152.4	4-5/8	160	8-M16	160	8-M16	158	95	46	79	390	140.5	165	-
100	4"	190.5	8-5/8	180	8-M16	180	8-M16	175	114	52	104	476	154	211.5	-
125	5"	215.9	8-3/4	210	8-M16	210	8-M16	190	127	54.4	123.3	485	154	211.5	-
150	6"	241.3	8-3/4	240	8-M20	240	8-M20	211	139	55.8	155.1	553	186	259	-
200	8"	298.5	8-3/4	295	12-M20	295	12-M20	235	175	60.6	202.5	613	186	259	-
250	10"	361.9	12-7/8	350	12-M20	355	12-M24	265	203	65.5	250.5	671	186	259	-
300	12"	431.8	12-7/8	400	16-M20	410	16-M24	305	242	76.9	301.5	771	193	283.5	-

Technical Material List

APPLICABLE STANDARDS & TECHNICAL NOTES:							
DESIGN CODE		API609		END STANDARD		ANSI 150#/JIS 10K	
INSPECTION&TEST		API598		FACE TO FACE		API609	
NO.	PARTS NAME	MATERIAL	QTY	NO.	PARTS NAME	MATERIAL	QTY
1	BODY	DI/WCB/CF8/CF8M	1	4	SEAT	NBR/EPDM/PTFE/VITON	1
2	DISC	WCB/DI+NYLON/CF8/CF8M	1	5	BUSHING	PTFE	4
3	SHAFT	SS410	1	6	O-RING	NBR	1
TEST PRESSURE							
		SHELL		SEAL			
HYDROSTATIC		24/15 kg/cm ²		17.6/11 kg/cm ²			
AIR		—		—			
TITLE: AN EAR BUTTERFLY VALVE							
SIZE		DN50-DN300		DWG NO.		FT0114000002-1	

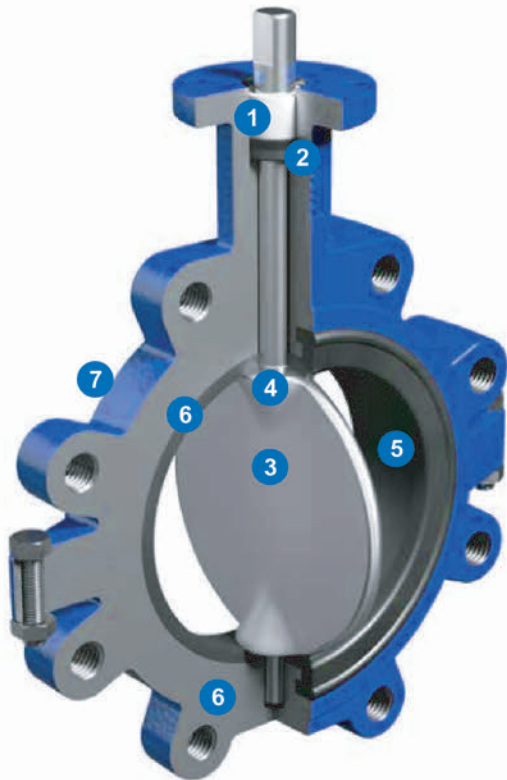

1 – STEM BUSHING: Non-corrosive, heavy duty acetal bushing absorbs actuator side thrust.

2 – STEM SEAL: Double “U” cup seal design is self-adjusting and gives positive sealing in both directions.

3 – DISC/STEM: One piece design. The disc edge is spherically machined and hand polished to produce a bubble tight shutoff, minimum torque, and longer seat life. For erosion and abrasion resistance, the one piece disc/stem is available encased in either EPDM or BUNA-N.

4 – PRIMARY AND SECONDARY SEALS: These seals prevent line media from coming in contact with the stem or body. Primary seal is achieved by an interference fit of the molded seat flat with the disc hub. Secondary seal is created because the stem diameter is greater than the diameter of the seat stem hole.

5 – SEAT: Flowx’s tongue and groove seat design provides complete isolation of flowing media from the body. The seat also features a molded o-ring which eliminates the need of flange gaskets.

6 – BODY: Two piece wafer or lug style allows for ease of assembly and maintenance.

7 – BODY COATINGS: For excellent corrosion resistance, Nylon 11 coating is standard for 1”- 8” valves and available on larger sizes upon request. Polyester coating is standard for 10”-20” bodies.

VENTILATION BUTTERFLY VALVE



Product Description

- Ventilation butterfly valve uses the aluminum alloy material as the valve body to process the seal ring and adopts electric or pneumatic actuator.
- The applicable temperature depends on the valve body selection, nominal pressure $\leq 0.6\text{MPa}$, generally applicable to industrial, metallurgical, environmental protection and other pipelines for ventilation regulation media flow use.
- Ventilation butterfly valves are used in the dusty cold air or hot air gas pipelines in the ventilation and environmental protection projects in the chemical, building materials, power stations, and glass industries, as a gas medium to regulate the flow or cut off the pipeline control devices.
- This type of valve should generally be installed horizontally in the pipeline.
- When the ventilating butterfly valve is in the fully open position, the thickness of the ventilating disc is the resistance when the medium flows through the valve body, so the pressure drop generated by the valve is very small, so it has better flow control characteristics.



Main Specification

Nominal Size	Operated Type	Pressure	Temperature	Seal/Disc/Body Material	Medium	Application	Connection Standard
DN80	Pneumatic Actuator	PN6	-15-430°C	Cast Iron	Waste Gas	VTO Incinerator	PN10/PN16
↓ 2000	Electric Actuator	PN10		Stainless Steel	Smoke	Ventilating Pipe	ANSI150
	Manual Hand Lever	PN16		Alloy Steel	Aeration		DIN16
	Worm Gear			Chromium			JIS10K/16K
				Molybdenum Steel Other Special Materials			

Seal Material Option And Applicable Temperature

Materials	Carbon Steel	Low Carbon Steel	Alloy Steel		Austenitic Stainless Steel	Chromium-molybdenum Steel
Code	WCB	LCB	WC6/WC9	C6/C9	Cr18/304/316	12CrMoV
Max Tem	425°C	345°C	595°C	650°C	600°C	560°C
Min Tem	-29°C	-46°C	-29°C	-29°C	-196°C	-40°C
Working temperature	$\leq 425^\circ\text{C}$	$\leq 345^\circ\text{C}$	$\leq 595^\circ\text{C}$	$\leq 650^\circ\text{C}$	$\leq 600^\circ\text{C}$	$\leq 560^\circ\text{C}$

Visit our website to know more details: www.flowxcontrol.com

Manual Handle Lever Operated

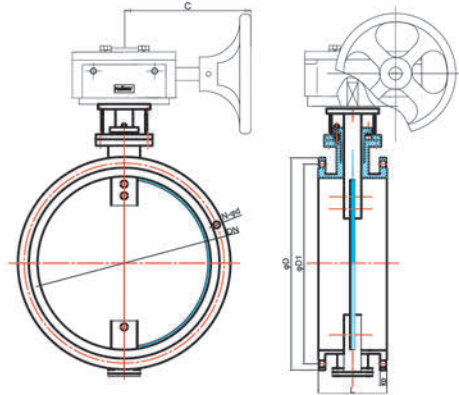

unit: mm

■ Dimensions

Size		b	L	D	D1	N-Φd	C
DN	NPS						
80	3"	14	110	185	150	4-Φ18	99
100	4"	14	110	205	170	4-Φ18	99
150	6"	16	110	260	225	8-Φ18	115
200	8"	18	140	315	280	8-Φ18	115
250	10"	18	140	370	335	12-Φ18	115
300	12"	20	170	435	395	12-Φ23	115
350	14"	20	170	485	445	12-Φ23	115
400	16"	20	190	535	495	16-Φ23	220
450	18"	22	190	590	550	16-Φ23	220
500	20"	22	190	640	600	16-Φ23	220

Worm Gear Operated

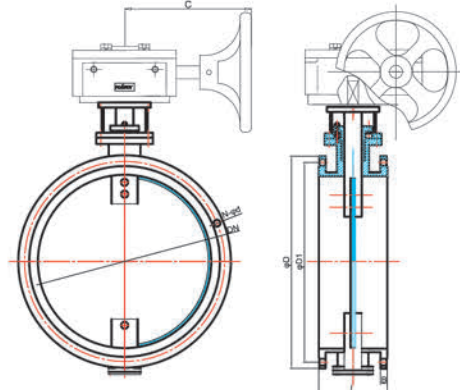

unit: mm

■ Dimensions

Size		b	L	D	D1	N-Φd	C
DN	NPS						
80	3"	14	110	185	150	4-Φ18	99
100	4"	14	110	205	170	4-Φ18	99
150	6"	16	110	260	225	8-Φ18	115
200	8"	18	140	315	280	8-Φ18	115
250	10"	18	140	370	335	12-Φ18	115
300	12"	20	170	435	395	12-Φ23	115
350	14"	20	170	485	445	12-Φ23	115
400	16"	20	190	535	495	16-Φ23	220
450	18"	22	190	590	550	16-Φ23	220
500	20"	22	190	640	600	16-Φ23	220

VENTILATION BUTTERFLY VALVE



Pneumatic Actuator Operated

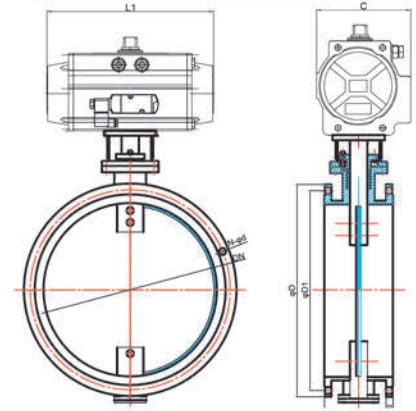

unit: mm

■ Dimensions

Size		b	L	D	D1	N-Φd	L1	C
DN	NPS							
80	3"	14	110	185	150	4-Φ18	237.5	106
100	4"	14	110	205	170	4-Φ18	237.5	106
150	6"	16	110	260	225	8-Φ18	271.5	123
200	8"	18	140	315	280	8-Φ18	271.5	123
250	10"	18	140	370	335	12-Φ18	328	137
300	12"	20	170	435	395	12-Φ23	328	137
350	14"	20	170	485	445	12-Φ23	366	148
400	16"	20	190	535	495	16-Φ23	366	148
450	18"	22	190	590	550	16-Φ23	428	164
500	20"	22	190	640	600	16-Φ23	428	164

Electric Actuator Operated

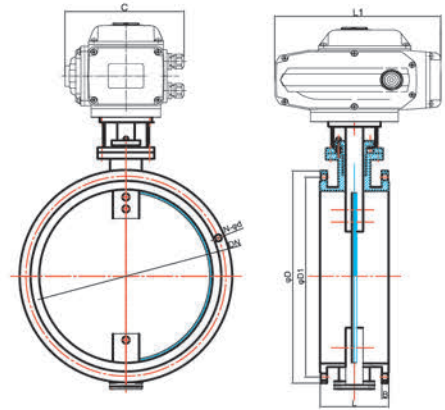

unit: mm

■ Dimensions

Size		b	L	D	D1	N-Φd	L1	C
DN	NPS							
80	3"	14	110	185	150	4-Φ18	211.5	154
100	4"	14	110	205	170	4-Φ18	211.5	157
150	6"	16	110	260	225	8-Φ18	259	186
200	8"	18	140	315	280	8-Φ18	259	186
250	10"	18	140	370	335	12-Φ18	259	186
300	12"	20	170	435	395	12-Φ23	259	186
350	14"	20	170	485	445	12-Φ23	259	186
400	16"	20	190	535	495	16-Φ23	259	186
450	18"	22	190	590	550	16-Φ23	259	186
500	20"	22	190	640	600	16-Φ23	259	186

Product Description

- Simple structure, good interchangeability, and low price.
- The stem seal is not easily deformed to avoid the normal stem leakage, and the overall support is good, stable and firm.
- With less seat rubber, there is less potential for expansion and it is easier to control the torque within the proper range.
- The use of two-piece valve stems with no pin connection, the structure is simple and compact, and maintenance and disassembly are very convenient.
- The butterfly board has the function of automatic centering, and the butterfly board and valve seat are closely matched.

The phenolic back valve seat has the characteristics of not falling off, tensile resistance, leakage prevention and easy replacement.

- Surface: Polyester, RAL9006, 100μ
- Face-to-face: EN558-1
- Counter flange: DN40-DN300, PN10/16/ANSI150
- BS10 TABLE D/E, JIS 10K, 16K
- DN350 -DN600 PN10 or ANSI150 BS10 TABLE D/E



Main Specification

Nominal Size	Operated Type	Pressure	Temperature	Seal Material	Disc Material	Body Material	Medium	Application	Connection Standard
DN50 ↓ 350	Pneumatic Actuator	PN2	-15-85°C	PTFE	WCB	Ductile Iron	Strong Acid Strong Alkali Fodder	Water Gas Fodder	PN10/PN16
	Electric Actuator	PN1.0	-15-150°C	EPDM	SS304				ANSI150
	Manual Hand Lever	PN1.6		SS316	DIN16				
	Worm Gear				Polishing Plate				JIS10K/16K

Visit our website to know more details: www.flowxcontrol.com

U TYPE FLANGED BUTTERFLY VALVE



Manual Handle Lever Operated

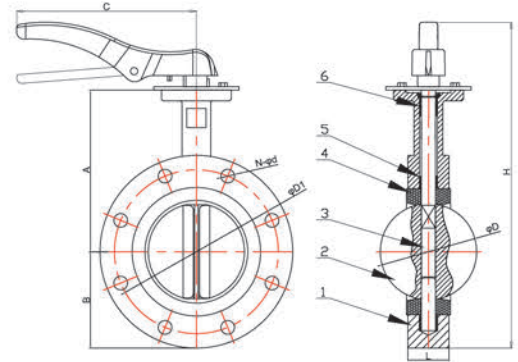

■ Dimensions

unit: mm

Size		CLASS150		JIS 10K		PN10		PN16		A	B	ΦD	L	H	C	WT (kg)
DN	NPS	D1	N-Φd1	D1	N-Φd1	D1	N-Φd1	D1	N-Φd1							
50	2"	120.6	4-Φ19.1	120	4-Φ19	125	4-Φ19	125	4-Φ19	161	83	52.9	42	312	213	-
65	2½"	139.7	4-Φ19.1	140	4-Φ19	145	4-Φ19	145	4-Φ19	175	93	64.5	45	336	213	-
80	3"	152.4	4-Φ19.1	150	8-Φ19	160	8-Φ19	160	8-Φ19	181	95	78.8	46	344	213	-
100	4"	190.5	8-Φ19.1	175	8-Φ19	180	8-Φ19	180	8-Φ19	200	114	104	52	403	277	-
125	5"	215.9	8-Φ22.4	210	8-Φ23	210	8-Φ19	210	8-Φ19	213	127	123.3	55	429	277	-
150	6"	241.3	8-Φ22.4	240	8-Φ23	240	8-Φ23	240	8-Φ23	226	139	155.1	56	454	277	-
200	8"	298.5	8-Φ22.4	290	12-Φ23	295	8-Φ23	295	12-Φ23	260	175	202.5	61	-	-	-
250	10"	361.9	12-Φ22.4	355	12-Φ25	350	12-Φ23	355	12-Φ28	292	203	250.5	66	-	-	-
300	12"	431.8	12-Φ22.4	400	16-Φ25	400	12-Φ23	410	12-Φ28	337	242	301.5	77	-	-	-
350	14"	476	12-Φ28.5	445	16-Φ25	460	16-Φ23	470	16-Φ28	368	267	333.3	77	-	-	-

Worm Gear Operated

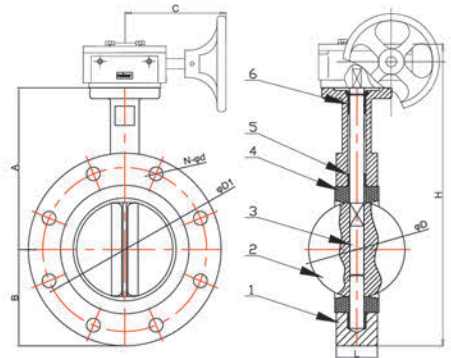

■ Dimensions

unit: mm

Size		CLASS150		JIS 10K		PN10		PN16		A	B	ΦD	L	H	C	WT (kg)
DN	NPS	D1	N-Φd1	D1	N-Φd1	D1	N-Φd1	D1	N-Φd1							
50	2"	120.6	4-Φ19.1	120	4-Φ19	125	4-Φ19	125	4-Φ19	161	83	52.9	42	292	99	-
65	2½"	139.7	4-Φ19.1	140	4-Φ19	145	4-Φ19	145	4-Φ19	175	93	64.5	45	316	99	-
80	3"	152.4	4-Φ19.1	150	8-Φ19	160	8-Φ19	160	8-Φ19	181	95	78.8	46	324	99	-
100	4"	190.5	8-Φ19.1	175	8-Φ19	180	8-Φ19	180	8-Φ19	200	114	104	52	362	99	-
125	5"	215.9	8-Φ22.4	210	8-Φ23	210	8-Φ19	210	8-Φ19	213	127	123.3	55	394	115	-
150	6"	241.3	8-Φ22.4	240	8-Φ23	240	8-Φ23	240	8-Φ23	226	139	155.1	56	419	115	-
200	8"	298.5	8-Φ22.4	290	12-Φ23	295	8-Φ23	295	12-Φ23	260	175	202.5	61	506	220	-
250	10"	361.9	12-Φ22.4	355	12-Φ25	350	12-Φ23	355	12-Φ28	292	203	250.5	66	566	220	-
300	12"	431.8	12-Φ22.4	400	16-Φ25	400	12-Φ23	410	12-Φ28	337	242	301.5	77	650	220	-
350	14"	476	12-Φ28.5	445	16-Φ25	460	16-Φ23	470	16-Φ28	368	267	333.3	77	715	323	-

Pneumatic Actuator Operated

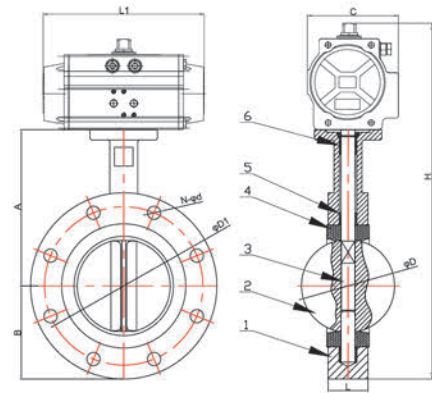

Dimensions

unit: mm

Size		CLASS150		JIS 10K		PN10		PN16		A	B	ΦD	L	H	L1	C	WT (kg)
DN	NPS	D1	N-Φd1	D1	N-Φd1	D1	N-Φd1	D1	N-Φd1								
50	2"	120.6	4-Φ19.1	120	4-Φ19	125	4-Φ19	125	4-Φ19	161	83	52.9	42	333.5	139.5	71	-
65	2½"	139.7	4-Φ19.1	140	4-Φ19	145	4-Φ19	145	4-Φ19	175	93	64.5	45	368.5	162	80.5	-
80	3"	152.4	4-Φ19.1	150	8-Φ19	160	8-Φ19	160	8-Φ19	181	95	78.8	46	376.5	162	80.5	-
100	4"	190.5	8-Φ19.1	175	8-Φ19	180	8-Φ19	180	8-Φ19	200	114	104	52	431	207	95	-
125	5"	215.9	8-Φ22.4	210	8-Φ23	210	8-Φ19	210	8-Φ19	213	127	123.3	55	468.5	237.5	106	-
150	6"	241.3	8-Φ22.4	240	8-Φ23	240	8-Φ23	240	8-Φ23	226	139	155.1	56	542.5	271.5	123	-
200	8"	298.5	8-Φ22.4	290	12-Φ23	295	8-Φ23	295	12-Φ23	260	175	202.5	61	606.5	328	137	-
250	10"	361.9	12-Φ22.4	355	12-Φ25	350	12-Φ23	355	12-Φ28	292	203	250.5	66	678.5	366	148	-
300	12"	431.8	12-Φ22.4	400	16-Φ25	400	12-Φ23	410	12-Φ28	337	242	301.5	77	785	428	164	-
350	14"	476	12-Φ28.5	445	16-Φ25	460	16-Φ23	470	16-Φ28	368	267	333.3	77	857	430	186.5	-

Electric Actuator Operated

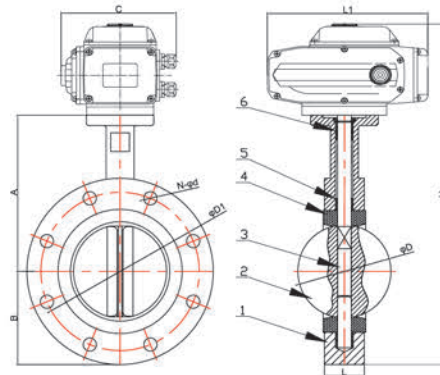

Dimensions

unit: mm

Size		CLASS150		JIS 10K		PN10		PN16		A	B	ΦD	L	H	L1	C	WT (kg)
DN	NPS	D1	N-Φd1	D1	N-Φd1	D1	N-Φd1	D1	N-Φd1								
50	2"	120.6	4-Φ19.1	120	4-Φ19	125	4-Φ19	125	4-Φ19	161	83	52.9	42	381.5	165	140.5	-
65	2½"	139.7	4-Φ19.1	140	4-Φ19	145	4-Φ19	145	4-Φ19	175	93	64.5	45	405.5	165	140.5	-
80	3"	152.4	4-Φ19.1	150	8-Φ19	160	8-Φ19	160	8-Φ19	181	95	78.8	46	413.5	165	140.5	-
100	4"	190.5	8-Φ19.1	175	8-Φ19	180	8-Φ19	180	8-Φ19	200	114	104	52	482.5	211.5	154	-
125	5"	215.9	8-Φ22.4	210	8-Φ23	210	8-Φ19	210	8-Φ19	213	127	123.3	55	508.5	211.5	154	-
150	6"	241.3	8-Φ22.4	240	8-Φ23	240	8-Φ23	240	8-Φ23	226	139	155.1	56	568	259	186	-
200	8"	298.5	8-Φ22.4	290	12-Φ23	295	8-Φ23	295	12-Φ23	260	175	202.5	61	638	259	186	-
250	10"	361.9	12-Φ22.4	355	12-Φ25	350	12-Φ23	355	12-Φ28	292	203	250.5	66	698	259	186	-
300	12"	431.8	12-Φ22.4	400	16-Φ25	400	12-Φ23	410	12-Φ28	337	242	301.5	77	808.5	283.5	193	-
350	14"	476	12-Φ28.5	445	16-Φ25	460	16-Φ23	470	16-Φ28	368	267	333.3	77	864.5	283.5	193	-

U TYPE FLANGED BUTTERFLY VALVE



Technical Material List

APPLICABLE STANDARDS & TECHNICAL NOTES:							
DESIGN CODE		API609		END STANDARD		ANSI 150#/JIS 10K	
INSPECTION&TEST		API598		FACE TO FACE		API609	
NO.	PARTS NAME	MATERIAL	QTY	NO.	PARTS NAEM	MATERIAL	QTY
1	BODY	DI/WCB/CF8/CF8M	1	4	SEAT	NBR/EPDM/PTFE/VITON	1
2	DISC	WCB/DI+NYLON/CF8/CF8M	1	5	BUSHING	PTFE	4
3	SHAFT	SS410	1	6	O-RING	NBR	1
TEST PRESSURE							
		SHELL		SEAL			
HYDROSTATIC		24/15 kg/cm ²		17.6/11 kg/cm ²			
AIR		—		—			
TITLE: U TYPE FLANGED BUTTERFLY VALVE							
SIZE		DN50-DN350		DWG NO.		FT0114000003-1.1	

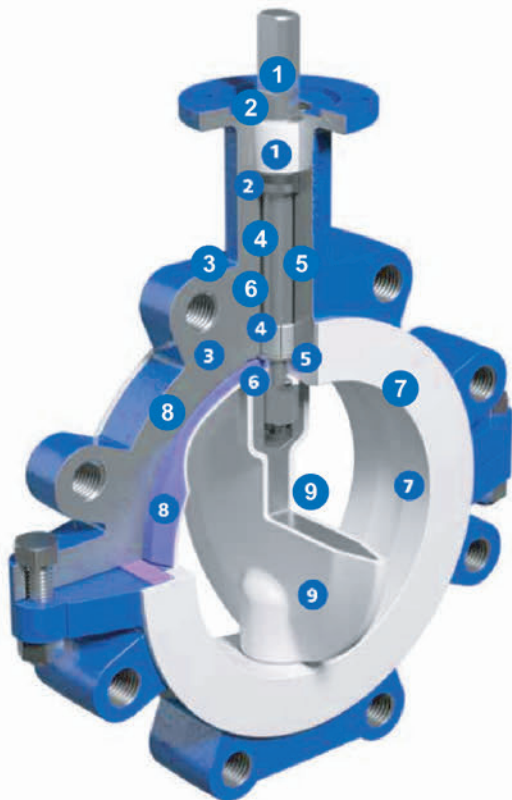

1 – UPPER STEM BUSHING: An upper stem bushing, retained by a stainless steel ring, is provided to absorb actuator side thrusts and is acetal as standard or PTFE as an option.

2 – UPPER STEM SEAL: Keeps environmental contaminants from entering the stem bore.

3 – BODY: Bodies are two piece wafer or lug style and are epoxy coated. All bodies meet full ASME Class 150 OR DIN 3840 flange drilling requirements (24" body is double flanged).

4 – BEARINGS: PTFE impregnated steel bearings provided for the precision alignment of the upper and lower stem.

5 – BLOWOUT PROOF STEM: A shoulder is machined into the upper stem. The stem and the disc are pressed together during assembly creating a positive stem to disc connection.

6 – PRIMARY SEAL: The primary seal is achieved by an interference fit between the extra wide disc hubs and contoured seat.

7 – SEAT DESIGN: The unique seat geometry lowers seating and unseating torque while reducing wear on the contacting parts.

8 – SEAT ENERGIZER: A resilient seat energizer extends completely around the seat, including the disc hub providing uniform force sufficient for bubble tight shutoff.

9 – DISC: The encapsulated disc has 1/8" (3 mm) minimum thickness of virgin PTFE or PFA lined over stainless steel.

Product Description

- FLOWX series powder pneumatic butterfly valve is used advanced Italian technology by first-class engineers to make bold breakthroughs and innovations in the material technology and a new development of a powder, granular materials, material delivery Since the advent of new industrial products and products, it has created a series of successful applications in extremely harsh environments with granular media, and is very popular by owners and technical engineers in the powder industry.
- The valve body is made of lightweight high-pressure cast aluminum alloy with light weight. valve plate is lined with a steel core of wear-resistant polymer materials, and wear-resistant rubber seals to form a high wear resistance soft seal, wear and then strong can also be applied.
- The application of granular materials, especially for abrasive materials, in powder and granular material processing systems that require gravity blanking or pneumatic conveying. It is suitable for powder and particle materials with gravity blanking and gas conveying. Processing system. is specially used for powder/cement material industry products. Installed in the hopper, silo, scre.
- Single Flanged(S) and Double Flanged(D) is for your reference.



■ FLOWX-S:

1	Bracket	Cast Aluminium Alloy
2	Shaft Sleeve	Nylon
3	Body	Cast Aluminium Alloy
4	Disc	Wear Resistant Polymer Material
5	Sealing Ring	NBR
6	Shaft Sleeve	Nylon
7	Body	Cast aluminium alloy



■ FLOWX-A:

1	Bracket	Cast Aluminium Alloy
2	Shaft Sleeve	Nylon
3	Body	Cast Aluminium Alloy
4	Disc	SS304/316
5	300	Rubber
6	Sealing Ring	Nylon
7	Shaft Sleeve	Cast Aluminium Alloy



■ Main Specification

Nominal Size	Operated Type	Work Pressure	Work Temperature	Seal Material	Disc Material	Body Material	Medium	Application	Connection Standard
DN50 ↓ 350	Pneumatic Actuator	PN0.1	-15-85°C	EPDM	SS304	WCB	Dust	Rubbe	PN10/PN16
	Electric Actuator			NBR	SS316				Fodder
	Manual Hand Lever			VITON			Cement	Pharmacy	DIN16
	Worm Gear								JIS10K/16K

Disc Material Wear Resistant Polymer **Body Material** Aluminum Casting Alloy **Medium** Others Powder Granule Materials
Application Coal Chemical Industry, Petrochemical Industry

Visit our website to know more details: www.flowxcontrol.com

POWDER BUTTERFLY VALVE



Manual Handle Lever Operated

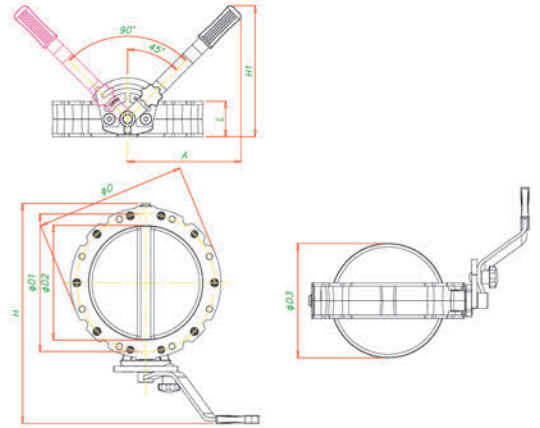

Dimensions

unit: mm

Size		D	D1	D2	D3	H	H1	L	A
DN	NPS								
100	4"	220	180	100	100	354	286	77	247
150	6"	228	200	150	150	380	286	77	247
200	8"	278	250	200	200	430	286	77	247
250	10"	328	300	250	250	480	286	77	247
300	12"	378	350	300	300	530	286	77	247
350	14"	440	400	350	350	537	413	85	370
400	16"	530	470	400	400	594	413	85	370

Pneumatic Actuator Operated

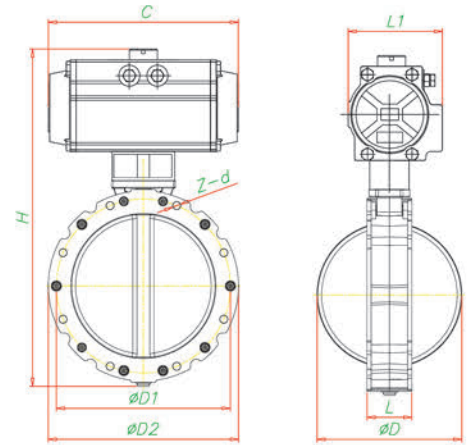

unit: mm

Dimensions

Size		D	D1	D2	Z-d	L	L1	C	H
DN	NPS								
100	4"	100	180	220	4-Φ14	77	94.5	208	373
150	6"	150	200	228	4-Φ14	77	109	245	417
200	8"	200	250	278	4-Φ14	77	123	266	474
250	10"	250	300	328	8-Φ14	77	137	328	573
300	12"	300	350	378	8-Φ14	77	148	340	633
350	14"	350	400	440	8-Φ14	85	168.5	401	721
400	16"	400	470	530	8-Φ14	85	168.5	430	779

Electric Actuator Operated

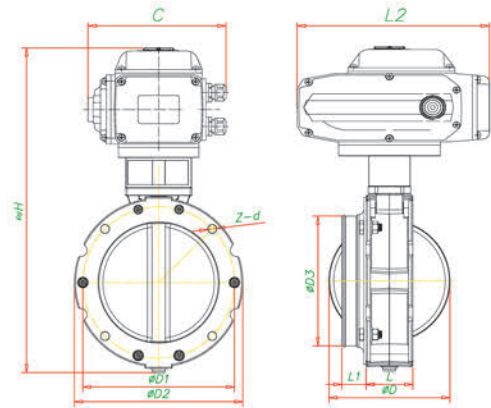

unit: mm

Dimensions

Size		D	D1	D2	D3	Z-d	L	L1	L2	C	H
DN	NPS										
100	4"	100	180	220	108	4-Φ14	77	40	211.5	154	424
150	6"	150	200	228	164	4-Φ14	77	40	259	186	484
200	8"	200	250	278	214	4-Φ14	77	40	259	186	535
250	10"	250	300	328	264	8-Φ14	77	40	259	186	604
300	12"	300	350	378	314	8-Φ14	77	40	259	186	652
350	14"	350	400	440	362	8-Φ14	85	40	259	186	715
400	16"	400	470	530	412	8-Φ14	85	40	283.5	193	787

Technical Material List

APPLICABLE STANDARDS & TECHNICAL NOTES:							
DESIGN CODE		EN593/BS5155/API609		END STANDARD		EN1092/PN10/ANSI 150#/JIS 10K	
INSPECTION&TEST		EN12266-1/API598		FACE TO FACE		EN558-1/API609	
NO.	PARTS NAEM	MATERIAL		NO.	PARTS NAEM	MATERIAL	
1	BODY	PVC/CPVC/FR-PP		4	O-RING	EPDM/FPM	
2	SEAT	EPDM/FPM		5	STEM	45/420/304/316	
3	DISC	PVC/CPVC/FR-PP					
TEST PRESSURE							
		SHELL			SEAL		
HYDROSTATIC		24/15 kg/cm ²			17.6/11 kg/cm ²		
AIR		—			—		
TITLE: POWDER BUTTERFLY VALVE							
SIZE		DN50-DN200		DWG NO.		FP1030I111G6	

UPVC PLASTIC BUTTERFLY VALVE



Product Description

- UPVC plastic butterfly valve body with light weight, strong corrosion resistance, compact and beautiful appearance, light weight body easy to install, a wide range of applications, material hygiene without DU, wear-resistant, easy to disassemble, easy maintenance, suitable for fluid: water , air, oils, corrosive chemical liquids, etc.
- RPP -20°C~90°C • UPVC -10°C~70°C • CPVC -40°C~95°C • PPH -20°C~95°C
- Valve body light weight, strong corrosion resistance
- Compact and beautiful appearance
- The body is light and easy to install
- High corrosion resistance, wide application range

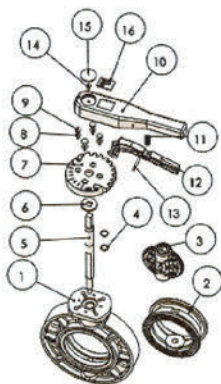

UPVC Butterfly Valve Handle Material:

NO.	PARTS NAME	MATERIAL	QTY
1	Body	PVC\CPVC\PPG\PPH	1
2	Seat	EPDM\FPM	1
3	Body	PVC\CPVC\PPG\PPH	1
4	Disc	EPDM\FPM	2
5	O-Ring	SS304\SS316	1
6	Handle	ABS	1
7	Spring	SS304	1
8	Lever	ABS	1
9	Bearing	PP-GF	1

Main Specification

Nominal Size	Operated Type	Work Pressure	Work Temperature	Seal Material	Disc/Body Material	Medium	Application	Connection Standard
DN50	Pneumatic Actuator	PN0.6	-15-85°C	PTFE	UPVC	Potable Water	Chemical Industry	PN10/PN16
↓	Electric Actuator	PN1.0		EPDM	CPV	Sewage	Agriculture	ANSI150
	Manual Hand Lever				PPG	High Purity Water	Pharmacy	DIN16
200	Worm Gear				FRPP		Environmental Protection	JIS10K/16K
					PPH			
					PP			
					PP-R			
					ABS			

Visit our website to know more details: www.flowxcontrol.com

Manual Handle Lever Operated

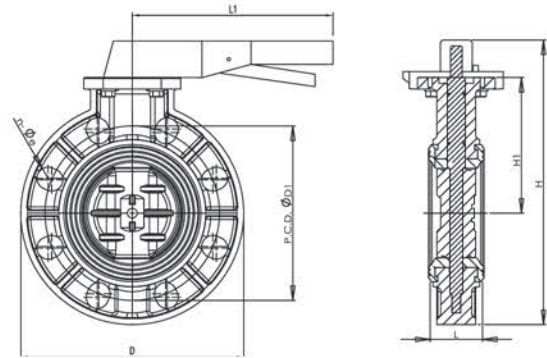

Dimensions

unit: mm

Size		DIN		ANSI 150		JIS 10K		T	H1	L	L1	H	C1	E	F	4-C
DN	NPS	n-Φe	P.C.D.ΦD1	n-Φe	P.C.D.ΦD1	n-Φe	P.C.D.ΦD1									
50	2"	4-Φ19	125	4-Φ19	121	4-Φ19	120	12	100	43	190	223	140.5	65	50	4-7
65	2½"	4-Φ19	145	4-Φ19	140	4-Φ19	140	12	112	46	190	245	140.5	65	50	4-7
80	3"	8-Φ19	160	4-Φ19	152	8-Φ19	150	12	120	49	240	270	140.5	65	50	4-7
100	4"	8-Φ19	180	8-Φ19	191	8-Φ19	175	12	140	54	240	308	154	65	50	4-7
														90	70	4-10
125	5"	8-Φ19	210	8-Φ19	216	8-Φ19	210	15	168	64	310	352	154	90	70	4-10
150	6"	8-Φ23	240	8-Φ23	241	8-Φ23	240	15	181	70	310	382	186	90	70	4-10
200	8"	8-Φ23	295	8-Φ23	298	8-Φ23	290	15	215	88	-	-	186	125	102	4-12

Worm Gear Operated

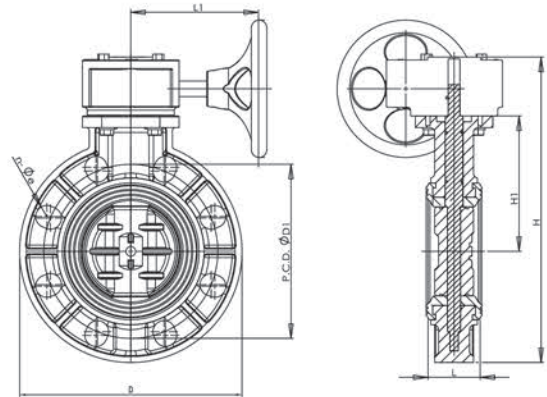

Dimensions

unit: mm

Size		DIN		ANSI 150		JIS 10K		T	H1	L	L1	H	C1	E	F	4-C
DN	NPS	n-Φe	P.C.D.ΦD1	n-Φe	P.C.D.ΦD1	n-Φe	P.C.D.ΦD1									
50	2"	4-Φ19	125	4-Φ19	121	4-Φ19	120	12	100	43	99	228	140.5	65	50	4-7
65	2½"	4-Φ19	145	4-Φ19	140	4-Φ19	140	12	112	46	99	250	140.5	65	50	4-7
80	3"	8-Φ19	160	4-Φ19	152	8-Φ19	150	12	120	49	99	266	140.5	65	50	4-7
100	4"	8-Φ19	180	8-Φ19	191	8-Φ19	175	12	140	54	99	302	154	65	50	4-7
														90	70	4-10
125	5"	8-Φ19	210	8-Φ19	216	8-Φ19	210	15	168	64	115	351	154	90	70	4-10
150	6"	8-Φ23	240	8-Φ23	241	8-Φ23	240	15	181	70	115	389	186	90	70	4-10
200	8"	8-Φ23	295	8-Φ23	298	8-Φ23	290	15	215	88	220	487	186	125	102	4-12

UPVC PLASTIC BUTTERFLY VALVE



Pneumatic Actuator Operated

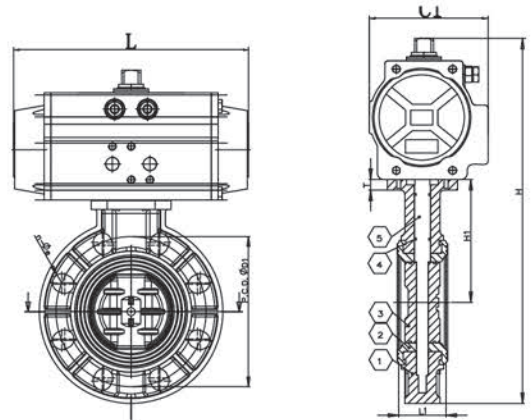

unit: mm

Dimensions

Size		DIN		ANSI 150		JIS 10K		T	H1	L	L1	H	C1	E	F	4-C
DN	NPS	n-Φe	P.C.D.ΦD1	n-Φe	P.C.D.ΦD1	n-Φe	P.C.D.ΦD1									
50	2"	4-Φ19	125	4-Φ19	121	4-Φ19	120	12	100	139.5	43	276.5	71	65	50	4-7
65	2½"	4-Φ19	145	4-Φ19	140	4-Φ19	140	12	112	162	46	300.5	80.5	65	50	4-7
80	3"	8-Φ19	160	4-Φ19	152	8-Φ19	150	12	120	162	49	325.5	80.5	65	50	4-7
100	4"	8-Φ19	180	8-Φ19	191	8-Φ19	175	12	140	207	54	378	95	65	50	4-7
														90	70	4-10
125	5"	8-Φ19	210	8-Φ19	216	8-Φ19	210	15	168	237.5	64	432.5	106	90	70	4-10
150	6"	8-Φ23	240	8-Φ23	241	8-Φ23	240	15	181	271.5	70	483	123	90	70	4-10
200	8"	8-Φ23	295	8-Φ23	298	8-Φ23	290	15	215	328	88	565.5	137	125	102	4-12

Electric Actuator Operated

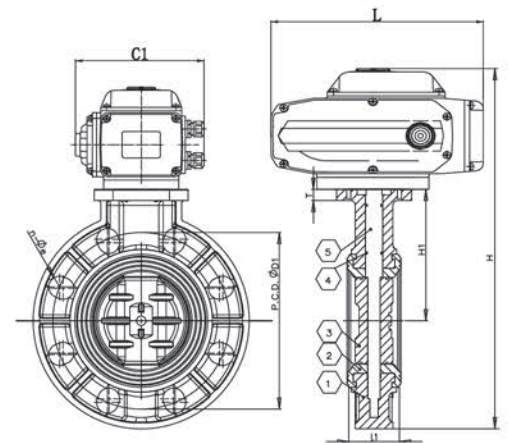

unit: mm

Dimensions

Size		DIN		ANSI 150		JIS 10K		T	H1	L	L1	H	C1	E	F	4-C
DN	NPS	n-Φe	P.C.D.ΦD1	n-Φe	P.C.D.ΦD1	n-Φe	P.C.D.ΦD1									
50	2"	4-Φ19	125	4-Φ19	121	4-Φ19	120	12	100	165	43	317.5	140.5	65	50	4-7
65	2½"	4-Φ19	145	4-Φ19	140	4-Φ19	140	12	112	165	46	339.5	140.5	65	50	4-7
80	3"	8-Φ19	160	4-Φ19	152	8-Φ19	150	12	120	165	49	355.5	140.5	65	50	4-7
100	4"	8-Φ19	180	8-Φ19	191	8-Φ19	175	12	140	211.5	54	422.5	154	65	50	4-7
														90	70	4-10
125	5"	8-Φ19	210	8-Φ19	216	8-Φ19	210	15	168	211.5	64	465.5	154	90	70	4-10
150	6"	8-Φ23	240	8-Φ23	241	8-Φ23	240	15	181	259	70	527.5	186	90	70	4-10
200	8"	8-Φ23	295	8-Φ23	298	8-Φ23	290	15	215	259	88	594	186	125	102	4-12

Product Description

- Hard-seal butterfly valve is a kind of component used to realize the on-off and flow control of pipeline system.
- It has been widely used in many fields such as petroleum, chemical industry, metallurgy, and hydropower. In the known butterfly valve technology, the sealing structure is mostly a sealed structure, and the sealing material is rubber, PTFE, and the like. Due to structural limitations, it is not suitable for high temperature, high pressure, corrosion and wear resistance industries.
- The existing one of the more advanced butterfly valves is a three-eccentric metal hard-seal butterfly valve.
- The valve body and the valve seat are connected components, and the valve seat sealing surface layer is surfacing with temperature-resistant and corrosion-resistant alloy materials.
- The multi-layer soft stack seal is fixed on the valve plate.
- Compared with the traditional butterfly valve, this type of butterfly valve has high temperature resistance, easy operation, no friction when opening and closing, and the seal is increased when the torque of the transmission mechanism is increased during closing.
- The sealing performance and the advantages of prolonged service life.



Main Specification

Nominal Size	Operated Type	Work Pressure	Work Temperature	Disc/Body Material	Medium	Application	Connection Standard
DN50	Pneumatic Actuator	0.6-4.0Mpa	WCB	WCB	Water	Food	GB/T9115.1-2000
↓	Electric Actuator		-15-85°C	SS304	Steam	Medicine	GB/T9115.2-2000
	Manual Hand Lever		Stainless Steel	SS316	Oil	Chemical Industry	ASME B16.5
	Worm Gear		-40°C-600°C		Acid Corrosion Ect	Power Plant Steel Mill Industrial environmental protection	ASME B 16.47

Visit our website to know more details: www.flowxcontrol.com

HARD SEAL TRIP ECCENTRIC BUTTERFLY VALVE



Pneumatic Actuator Operated

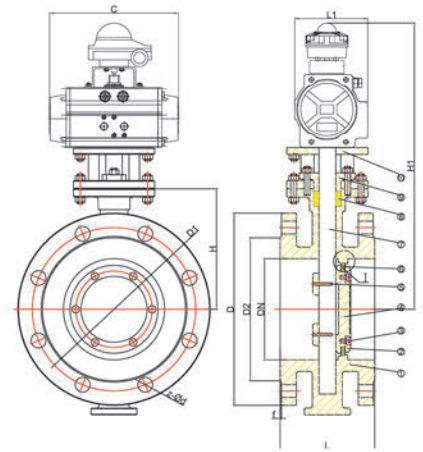

unit: mm

Dimensions

Size		SPRING RETURN				DOUBLE ACTING				L	D	D1	D2	f	Z	d	H
DN	NPS	H1	C	L1	WT (kg)	H1	C	L1	WT (kg)								
50	2"	374.5	273.5	106	DN	363	207	94.5	DN	108	155	125	102	2	4	18	160
65	2½"	402.5	271.5	123	DN	389.5	237.5	106	DN	112	185	145	122	2	8	18	175
80	3"	417.5	271.5	123	DN	404.5	237.5	106	DN	114	200	160	138	2	8	18	190
100	4"	452.5	328	137	DN	422.5	271.5	123	DN	127	220	180	152	2	8	18	195
125	5"	484.5	366	148	DN	472.5	328	137	DN	140	250	210	188	2	8	18	215
150	6"	517	428	164	DN	494.5	366	148	DN	140	285	240	212	2	8	22	225
200	8"	606	430	186.5	DN	590	428	164	DN	152	340	295	268	2	12	22	298
250	10"	666	482	204	DN	636	430	186.5	DN	165	405	350	320	2	12	26	328
300	12"	725	532	224	DN	703	482	204	DN	178	460	400	378	2	12	26	365
350	14"	812	662	266	DN	768	532	266	DN	190	520	460	428	2	16	26	408

Pneumatic Actuator Operated

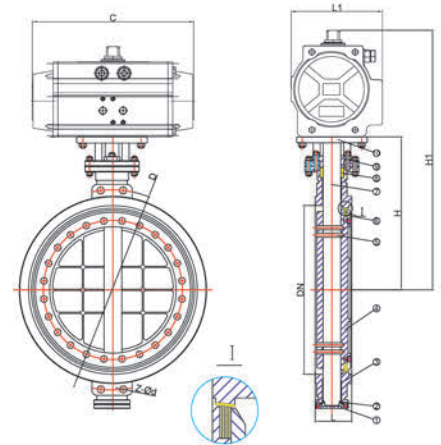

unit: mm

Dimensions

Size		PN16			PN25			DOUBLE ACTING				L	H
DN	NPS	D	Z	d	D	Z	d	H1	C	L1	WT (kg)		
50	2"	125	4	18	125	4	18	277	207	94.5	–	43	160
65	2½"	145	4	18	145	4	18	303.5	237.5	106	–	46	175
80	3"	160	4	18	160	4	18	318.5	237.5	106	–	49	190
100	4"	180	4	18	190	4	22	336.5	271.5	123	–	56	195
125	5"	210	4	18	220	4	26	386.5	328	137	–	64	215
150	6"	240	4	22	250	4	26	408.5	366	148	–	70	225
200	8"	295	4	22	310	4	26	504	428	164	–	71	298
250	10"	355	4	26	370	4	30	550	430	286.5	–	76	328
300	12"	410	4	26	430	4	30	617	482	204	–	83	365
350	14"	470	4	26	490	4	33	682	530	224	–	92	408

Electric Actuator Operated

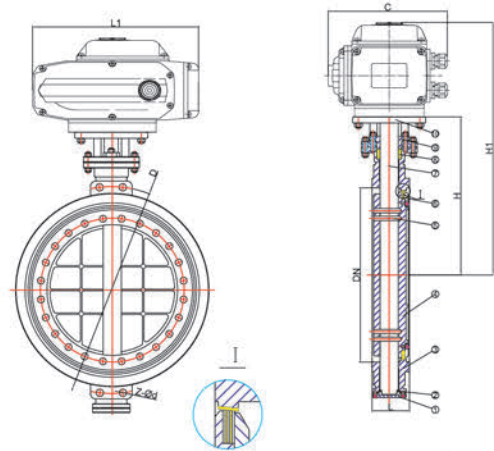

unit: mm

Dimensions

Size		PN16			PN25			L	H	H1	L1	C	WT (kg)
DN	NPS	D	Z	d	D	Z	d						
50	2"	125	4	18	125	4	18	43	160	328.5	211.5	154	DN
65	2½"	145	4	18	145	4	18	46	175	378	259	186	DN
80	3"	160	4	18	160	4	18	49	190	393	259	186	DN
100	4"	180	4	18	190	4	22	56	195	395	259	186	DN
125	5"	210	4	18	220	4	26	64	215	418	259	186	DN
150	6"	240	4	22	250	4	26	70	225	428	259	186	DN
200	8"	295	4	22	310	4	26	71	298	501	259	186	DN
250	10"	355	4	26	370	4	30	76	328	557.5	283.5	193	DN
300	12"	410	4	26	430	4	30	83	365	594.5	283.5	193	DN
350	14"	470	4	26	490	4	33	92	408	637.5	283.5	193	DN

Technical Material List

APPLICABLE STANDARDS & TECHNICAL NOTES:							
DESIGN CODE		GB/T 12236		END STANDARD		HG 20592	
INSPECTION&TEST		GB/T 13927		FACE TO FACE		GB/T 12221	
NO.	PARTS NAEM	MATERIAL	QTY	NO.	PARTS NAEM	MATERIAL	QTY
1	BODY	DI/WCB/CF8/CF8M	1	6	SEAL	304+FLEXIBLE GRAPHITE	1
2	PRESSURE RING	304	1	7	STEM	304	1
3	SCREW	304	1	8	PACKING	FLEXIBLE GRAPHITE	6
4	DISC	DI/WCB/CF8/CF8M	1	9	PACKING GLAND	DI/WCB/CF8/CF8M	1
5	PIN	304	1	10	STENTS	DI/WCB/CF8/CF8M	1
TEST PRESSURE							
		SHELL		SEAL			
HYDROSTATIC		24/37.5 kg/cm ²		17.6/27.5 kg/cm ²			
AIR		—		—			
TITLE: HARD SEAL TRIP ECCENTRIC BUTTERFLY VALVE							
SIZE		DN50-DN350		DWG NO.		FT0114000001-2	

HIGH PERFORMANCE BUTTERFLY VALVE



Product Description

- Triple eccentric butterfly valve can meet the requirements of high temperature, high pressure and strong corrosion, high wear and other working conditions, with light weight, compact structure, low operating torque, etc. can replace the conventional gate valve, globe valve and ball valve under most conditions.

High performance butterfly valve is a new type of butterfly valve designed based on the advantages of

- absorbing several different structural butterfly valves.

The valve plate sealing surface of this butterfly valve is a ball arc body, and the sealing mechanism achieves a true dynamic seal through the system pressure, so it has excellent cutting performance and durability performance. Its small size, light weight, a wide range of manufacturing, easy maintenance.

Features

- The sealing performance is good and the reliability of the system is improved.
- Small frictional resistance, open and close effort, flexibility.
- Long service life, can achieve repeated switching.
- High pressure and high temperature resistance, wide application range.



Main Specification

Nominal Size	Operated Type	Work Pressure	Work Temperature	Seal Material	Disc Material	Body Material	Medium	Application	Connection Standard
DN50	Pneumatic Actuator	1.6-6.3Mpa	-19-425°C	RPTFE	SS304	WCB	Strong Acid	Lithium Battery	JB/T79.1
	Electric Actuator				SS316 Stainless Steel		Strong Alkali	Desalination	JB/T79.2
350	Manual Hand Lever				SS316L		Strong Oxidant	Coal Chemical	HG20615
	Worm Gear				Chemical Industry		ASME B16.5		
					Rubber		ASME B 16.47		
							Papermaking		
							Pharmacy		

Visit our website to know more details: www.flowxcontrol.com

Handle Lever Operated

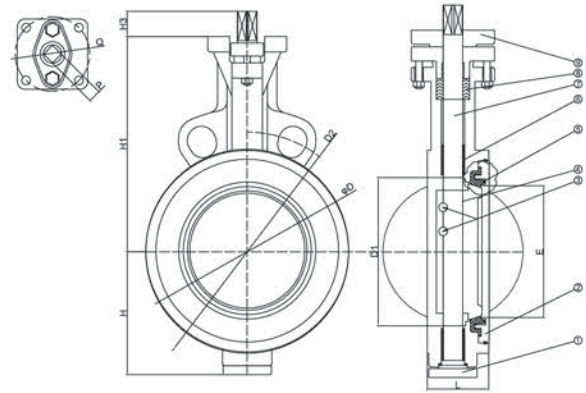

unit: mm

Dimensions

Size		D2			H1	H2	H3	L	D	D1	E	P	Q
DN	NPS	10K	PN16	150LB									
50	2"	120	125	120.5	65	138	16	43	96	48	40	11	F07
65	2½"	140	145	139.5	75	148	16	43	119	64	60	11	F07
80	3"	150	160	152.5	80	168	18	46	132	82	76	11	F07
100	4"	175	180	190.5	92	180	18	54	156	102	95	11	F07
125	5"	210	210	216	115	202	21	56	186	122	115	14	F07
150	6"	240	240	241.5	126	225	21	56	216	148	142	14	F010
200	8"	290	295	298.5	165	265	25	64	264	197	189	22	F010
250	10"	355	355	362	235	315	28	71	320	243	238	22	F012
300	12"	432	410	400	258	342	32	78	381	295	282	27	F012
350	14"	455	470	476	295	375	38	92	413	325	318	27	F014

Pneumatic Actuator Operated

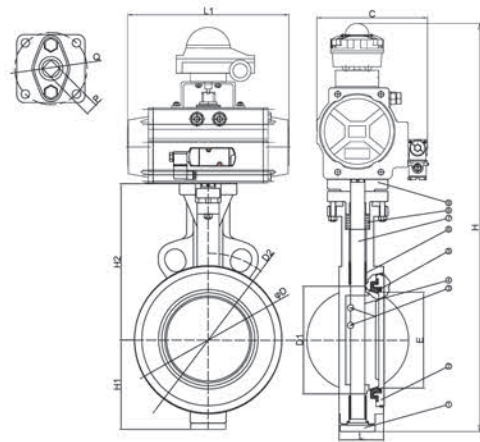

unit: mm

Dimensions

Size		D2			H1	H2	H	L	D	D1	E	P	Q
DN	NPS	10K	PN16	150LB									
50	2"	120	125	120.5	65	138	16	43	96	48	40	11	F07
65	2½"	140	145	139.5	75	148	16	43	119	64	60	11	F07
80	3"	150	160	152.5	80	168	18	46	132	82	76	11	F07
100	4"	175	180	190.5	92	180	18	54	156	102	95	11	F07
125	5"	210	210	216	115	202	21	56	186	122	115	14	F07
150	6"	240	240	241.5	126	225	21	56	216	148	142	14	F010
200	8"	290	295	298.5	165	265	25	64	264	197	189	22	F010
250	10"	355	355	362	235	315	28	71	320	243	238	22	F012
300	12"	432	410	400	258	342	32	78	381	295	282	27	F012
350	14"	455	470	476	295	375	38	92	413	325	318	27	F014

HIGH PERFORMANCE BUTTERFLY VALVE



Electric Actuator Operated

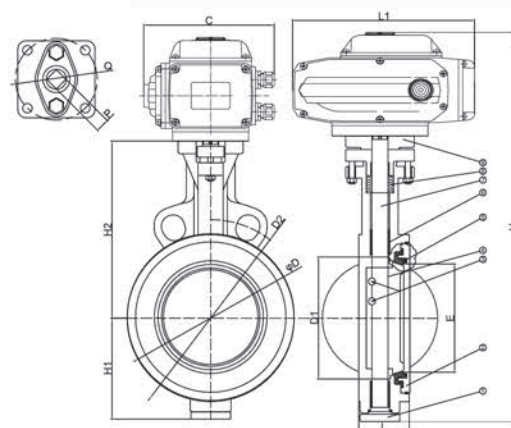

Dimensions

unit: mm

Size		D2			H1	H2	L	D	D1	E	P	Q	H	L1	C
DN	NPS	10K	PN16	150LB											
50	2"	120	125	120.5	65	138	43	96	48	40	11	F07	340.5	162	140.5
65	2½"	140	145	139.5	75	148	43	119	64	60	11	F07	391.5	211.5	154
80	3"	150	160	152.5	80	168	46	132	82	76	11	F07	416.5	211.5	154
100	4"	175	180	190.5	92	180	54	156	102	95	11	F07	475	259	186
125	5"	210	210	216	115	202	56	186	122	115	14	F07	520	259	186
150	6"	240	240	241.5	126	225	56	216	148	142	14	F010	554	259	186
200	8"	290	295	298.5	165	265	64	264	197	189	22	F010	633	259	186
250	10"	355	355	362	235	315	71	320	243	238	22	F012	753	259	186
300	12"	432	410	400	258	342	78	381	295	282	27	F012	829.5	283.5	193
350	14"	455	470	476	295	375	92	413	325	318	27	F014	899.5	283.5	193

Technical Material List

APPLICABLE STANDARDS & TECHNICAL NOTES:							
DESIGN CODE		API609		END STANDARD		ANSI 150#/JIS 10K	
INSPECTION&TEST		API598		FACE TO FACE		API609	
NO.	PARTS NAME	MATERIAL	QTY	NO.	PARTS NAEM	MATERIAL	QTY
1	LOCATING PLUG	WCB/CF8/CF8M	1	6	BEARING ASSEMBLY	304+PTFE	1
2	SEAT RETAINER PLATE	WCB/CF8/CF8M	1	7	STEM	17-4PH/410S	1
3	TAPER PINS	SS304	1	8	STEM SEAL	PTFE	1
4	DISC	SS304/306	1	9	BODY	WCB/CF8/CF8M	4
5	SEAT	PTFE	4				
TEST PRESSURE							
		SHELL		SEAL			
HYDROSTATIC		24/15 kg/cm ²		17.6/11 kg/cm ²			
AIR		—		—			
TITLE: HIGH PERFORMANCE BUTTERFLY VALVE							
SIZE		DN50-DN450		DWG NO.		FT0114000002-1	

Product Description

- Fire safety butterfly valve adopts the midline design.
- The main structure of the valve is composed of valve body, valve disc, valve seat, valve stem and transmission operating mechanism.
- The valve seat adopts detachable structure, transmission mechanism sub-handle, worm gear and worm Three types of signal and signal, suitable for fire sprinkler system water pipes, used for throttling or regulating flow, in which the signal valve is set on the switch position of the worm and is suitable for fire sprinkler systems.
- The valve seat adopts detaching design to facilitate on-site maintenance, and adopts the whole basin design, which is not easily blocked by impurities. The joint "O" sealing lines at both ends make the pipeline installation without the need of additional gaskets to maintain a reliable seal, and can be used according to different Requires different materials.
- The axle pin adopts the U.S. patented design of the withdrawal and withdrawal pin structure, which can tightly connect the valve flap shaft together without loosening and weakening the strength of the shaft and having good interchangeability.
- The operation structure is flexible and can be used to configure different rotation devices such as handles, worm gears and worm gears. The worm and worm gear can also be equipped with signal devices.



Main Specification

Nominal Size	Operated Type	Work Pressure	Work Temperature	Seal/Seat Material	Disc Material	Body Material	Medium	Application	Connection Standard
DN50	Pneumatic Actuator	1.0Mpa	-10°C-80°C	PTFE	EPDM	Ductile Iron	Water Oil Gas	Water Drainage Building Fire	PN10/PN16
↓	Electric Actuator	1.6Mpa		EPDM	PTFE	Cast Steel			ANSI150
	Manual Hand Lever	2.5Mpa							DIN16
300	Worm Gear						JIS10K/16K		

Visit our website to know more details: www.flowxcontrol.com

FIRE SAFETY BUTTERFLY VALVE



Manual Handle Lever Operated

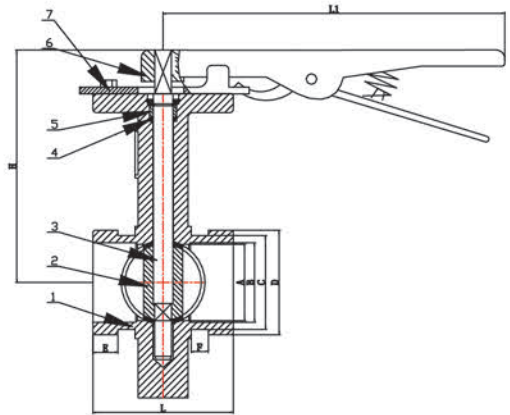

■ Dimensions

unit: mm

Size		A	B	C	D	E	F	L	H	L1	WT (kg)
DN	NPS										
50	2"	48.8	50	60.3	67	16	11	90	145	220	-
65	2½"	59.8	61	69.1	73	16	11	97	151.5	220	-
80	3"	79.1	78	88.9	97	16	11	97	157.5	220	-
100	4"	99	101	114.3	122.5	16	11	116	176	260	-
125	5"	123.8	127	137	141.3	16	11	134	199.5	260	-
150	6"	146.8	150	165	175	16	11	134	211	260	-
200	8"	198.8	202	219	232	20.5	11	148	-	-	-
250	10"	248.8	253	278	286	20.5	11	160	-	-	-
300	12"	298.8	303	323.9	336.5	20.5	11	166	-	-	-

Pneumatic Actuator Operated

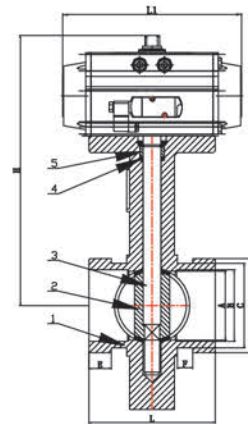

■ Dimensions

unit: mm

Size		A	B	C	D	E	F	L	H	L1	WT (kg)
DN	NPS										
50	2"	48.8	50	60.3	67	16	11	90	208.5	139.5	-
65	2½"	59.8	61	69.1	73	16	11	97	226	162	-
80	3"	79.1	78	88.9	97	16	11	97	232	162	-
100	4"	99	101	114.3	122.5	16	11	116	368	207	-
125	5"	123.8	127	137	141.3	16	11	134	300	237.5	-
150	6"	146.8	150	165	175	16	11	134	324.5	271.5	-
200	8"	198.8	202	219	232	20.5	11	148	377	328	-
250	10"	248.8	253	278	286	20.5	11	160	433.5	366	-
300	12"	298.8	303	323.9	336.5	20.5	11	166	481	428	-

Electric Actuator Operated

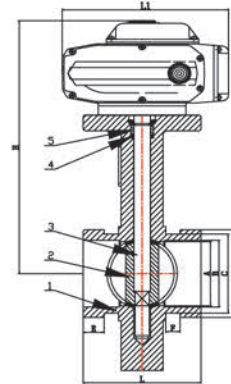

unit: mm

Dimensions

Size		A	B	C	D	E	F	L	H	L1	WT (kg)
DN	NPS										
50	2"	48.8	50	60.3	67	16	11	90	256.5	165	–
65	2½"	59.8	61	69.1	73	16	11	97	263	165	–
80	3"	79.1	78	88.9	97	16	11	97	269	165	–
100	4"	99	101	114.3	122.5	16	11	116	319.5	211.5	–
125	5"	123.8	127	137	141.3	16	11	134	340	211.5	–
150	6"	146.8	150	165	175	16	11	134	388	259	–
200	8"	198.8	202	219	232	20.5	11	148	408.4	259	–
250	10"	248.8	253	278	286	20.5	11	160	453	259	–
300	12"	298.8	303	323.9	336.5	20.5	11	166	467.5	283.5	–

Technical Material List

APPLICABLE STANDARDS & TECHNICAL NOTES:							
DESIGN CODE		API609		END STANDARD		ANSI 150#/JIS 10K	
INSPECTION&TEST		API598		FACE TO FACE		API609	
NO.	PARTS NAME	MATERIAL	QTY	NO.	PARTS NAME	MATERIAL	QTY
1	BODY	DI/WCB/CF8/CF8M	1	6	LEVER	MALLEBLE IRON	1
2	DISC	WCB/DI+NYLON/CF8/CF8M	1	7	INDICATOR	CARBON STEEL	1
3	SHAFT	SS410	1	8	HANDWHEEL	EPDM	1
4	BUSHING	PTFE	1	9	GEAR	CAST IRON	1
5	X-RING	EPDM	1				
TEST PRESSURE							
		SHELL		SEAL			
HYDROSTATIC		24/15 kg/cm ²		17.6/11 kg/cm ²			
AIR		—		—			
TITLE: WAFER BUTTERFLY VALVE							
SIZE		DN50-DN300		DWG NO.		FT011400002-1	

Product Description

- Sanitary Butterfly Valve is widely used in beer, beverage, dairy, juice, pharmacy and bioengineering.
- High performance for Sealed, long service life and Internal and external high-grade polishing equipment to achieve surface precision
- Working pressure: 0.6Mpa, 1.0Mpa, 1.6Mpa
- Working temperature: -10°C+100°C
- Applicable medium: liquid, gas, oil, all kinds of highly corrosive chemical media
- Applications: Food, Beverage, Pharmaceutical, Dairy, Beer and Fine Chemicals

Main Specification

Nominal Size	Operated Type	Connection Mode	Work Pressure	Work Temperature	Seal Material	Disc/Body Material	Medium	Application	Connection Standard
DN15	Pneumatic Actuator	Weld	0.6Mpa	10°C+100°C	EPDM	SUS304	Water	Food	ISO
	Electric Actuator	Socket	1.0Mpa		NBR	SUS316L	Gas	Beverages	DIN
	Manual Hand Lever	Threaded	1.6Mpa		PTFE		Oil	Pharmacy	IDF
150	Worm Gear	Clamped					Milk	SMS	
		Wafer					Beer	3A	
							Fine Chemicals		

Medium Various Highly Corrosive Chemical Media

Manual Handle Lever Operated

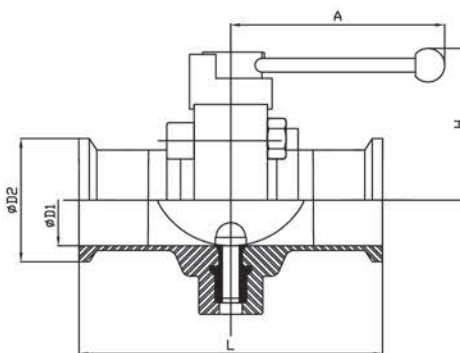

Dimensions

unit: mm

Size		D1	D2	A	L	H
DN	NPS					
50	3/4"	16.1	50.5	125	66	68
65	1"	22.4	50.5	125	66	68
80	1 1/4"	28.8	50.5	125	66	68
100	1 1/2"	35.1	50.5	125	66	72
125	2"	47.8	64	135	72	79
150	2 1/2"	59.5	77.5	135	76	86
100	3"	72.2	91	135	76	96
150	2 1/2"	85	106	160	84	101
200	4"	97.6	119	160	90	110
250	6"	154	183	230	132	147

Visit our website to know more details: www.flowxcontrol.com

Pneumatic Actuator Operated

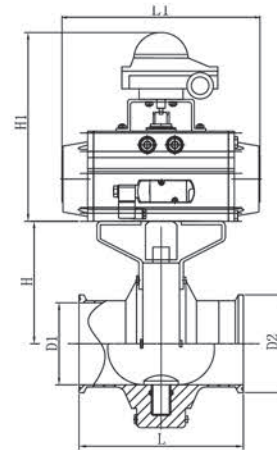

Dimensions

unit: mm

Size		D1	D2	L	H	SINGLE		DOUBLE	
DN	NPS					L1	H1	L1	H1
19	3/4"	16.1	50.5	66	69	162	193.5	139.5	182.5
25	1"	22.4	50.5	66	69	162	193.5	139.5	182.5
32	1 1/4"	28.8	50.5	66	69	162	193.5	139.5	182.5
38	1 1/2"	35.1	50.5	66	76	162	193.5	139.5	182.5
45	2"	42	64	70	81	162	193.5	139.5	182.5
51	2 1/2"	47.8	64	72	85	162	193.5	139.5	182.5
57	3"	53	77.5	76	88	207	210	162	193.5
63.5	2 1/2"	59.5	77.5	76	92	207	210	162	193.5
76	4"	72.5	91	76	99	207	210	162	193.5
89	6"	85	106	84	105	237.5	221.5	207	210

Electric Actuator Operated

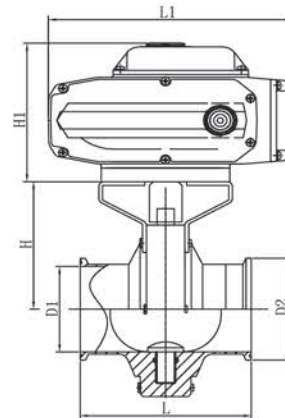

Dimensions

unit: mm

Size		D1	D2	L	H	L1	H1
DN	NPS						
19	3/4"	16.1	50.5	66	69	165	127.5
25	1"	22.4	50.5	66	69	165	127.5
32	1 1/4"	28.8	50.5	66	69	165	127.5
38	1 1/2"	35.1	50.5	66	76	165	127.5
45	2"	42	64	70	81	165	127.5
51	2 1/2"	47.8	64	72	85	165	127.5
57	3"	53	77.5	76	88	165	127.5
63.5	2 1/2"	59.5	77.5	76	92	165	127.5
76	4"	72.2	91	76	99	165	127.5
89	6"	85	106	84	105	211.5	145.5

PNEUMATIC /ELECTRIC ACTUATOR



FP Series Pneumatic Actuator

- Rack and pinion actuators available in double acting and spring returnicals
- Standard units have anodized aluminum bodies with polyster coated end caps
Internal bidirectional travel stops
- Seacorr coating for harsh enviroments
- SIL 3 capable • Integral porting • NAMUR accessory compatible



■ Main Specification

Torque size	Double Acting DA52-DA270
	Single Return SR52-SR270
Pressure Range	40-140PSI(2.8-10bar)
Media	Dry Compressed Air/Inlet Gas
	Standard to 93°C
Temperature Range	Low
	High
	Extreme High
	Performance

FLX series Electric Actuator

- The Series is a low profile,compact,powerful actuator with customer-friendly features
- Manual declutchable handle lever
- Local high visibility dome postion indicator
- Digital interface available
- Optional microprocessor based mouldulating control



■ Main Specification

Type	ON-OFF Type,4-20ma Intelligent regulated type
Voltage	AC 24V 224V 230V 380V
	DC 12V 24V
Standard Enclosure	NEMA Type 4.4x and NEMA 7

Visit our website to know more details:www.flowxcontrol.com

FLX-A Series Electric Pneumatic Positioner

- Precision digital control
- Zero bleed design
- Compatible with rotary or linear actuators for single and double acting applicatic
- Various housing options available
- Precise, microprocessor driven flow control and advanced communication
- Non-contacting position sensor technology
- Integral volume booster
- Connective and preventative maintenance self-diagnostic checks



FLX-2 Series, Air Filter Regulator, Metal Design

- Space-saving design with filter and regulator in a single unit Good regulating
- Characteristics with minimal hysteresis
- Two pressure gauge connectors for flexible installation
- With manual, semi-automatic or fully automatic condensate draining
- Setting values are secured by locking the rotary knob



FLX-2N Series Limit Switch Valve Status Monitors

- Discrete status monitor for quarter turn rotary actuators
- NEMA4.4X and IP66, IP67 ingress protection
- High visibility dome position indicator
- Up to 6 SPDT switches or non-contacting proximity switches
- Switch pre-wired to internal terminal block



FLX-2V Series High Flow 2/5Way, 2/3Way Solenoid Valves

- Weatherproof NEMA4, 4X and explosion proof housings available
- Flying leads to DIN Connectors
- Single or dual Coil
- 2/5 or 2/3 Operation
- NAMUR mounted
- High flow up to 1.4 Cv
- Intrinsically safe versions available



Visit our website to know more details: www.flowxcontrol.com

CAUTION

Pressure-temperature ratings and other performance data published in this catalog have been developed from our design calculation, in-house testing, field reports provided by our customers and/or published official standards or specifications. They are good only to cover typical applications as a general guideline to users of KITZ products introduced in this catalog.

For any specific application, users are kindly requested to contact KITZ Corporation for technical advice, or to carry out their own study and evaluation for proving suitability of these products to such an application. Failure to follow this request could result in property damage and/or personal injury, for which we shall not be liable.

While this catalog has been compiled with the utmost care, we assume no responsibility for errors, impropriety or inadequacy. Any information provided in this catalog is subject to from-time-to-time change without notice for error rectification, product discontinuation, design modification, new product introduction or any other cause that KITZ Corporation considers necessary. This edition cancels all previous issues.

Read instruction manual carefully before use.

NOTICE

If any products designated as strategic material in the Foreign Exchange and Foreign Trade Law, Cabinet Order Concerning Control of Export Trade, Cabinet order Concerning Control of Foreign Exchange and other related laws and ordinances ("Foreign Exchange Laws") are exported to any foreign country or countries, an export license issued by the Japanese Government will be required under the Foreign Exchange Laws.

Further, there may be cases where an export license issued by the government of the United States or other country will be required under the applicable export-related laws and ordinances in such relevant countries.

The contract shall become effective subject to that a relevant export license is obtained from the Japanese Government.



Scan the QR code to know more



Electric and Pneumatic Valve Instructions



Shanghai FLOWX Valve Co., Ltd.

Tel:021-54150349

Fax:021-54150271

E-mail:sales@flowxvalve.com

Web:www.flowxvalve.com

Add:B8, No.2988, Dongchuan Road, Minhang District, Shanghai, China.

1.The continuous upgrading of products may result in data changes without prior notice.

2.If there are unknown or special specifications, please contact our sales staff.

Contents

1. Inatallation of Butterfly Valve -----	Page1-2
2. Inatallation of Ball Valve -----	Page 3-4
3. Operation -----	Page 5-6
5. Fault analysis -----	Page 7-8
6. Adjustment and installation of electric actuator -----	Page 9-13
7. Installation instructions of pneumatic actuator -----	Page14-17

EDITION STATEMENT

FLOWX VALVE owns all copyrights to this document.

This document is not allowed to be changed, expanded, reproduced, or submitted to a third party without flowx written agreement, and this limitation applies to the corresponding drawings.

FLOWX VALVE have the right it change the handbook . No prior or direct notification is needed.

This manual is for reference only. FLOWX VALVE cannot be held accountable, if any errors and consequences arising from the use of this handbook.

Products specified in this manual are guaranteed, others are not.

PREFACE

Dear Customers,

The content of this installation and Operation manual are to allow your to install and adjust valves quickly and correctly.

Please read the instructions carefully and pay special attention to comments and warning notes.

Only qualified engineers can install, debug and maintain the valve. If you are have any questions about the valve, please contact us and we are happy to answer for you.

You can find our contact information in the cover of this manual.

🔧 Butterfly Valve Installation

After welding the flange to the pipe and cooling to the ambient temperature, the valve can be installed on the flange. Otherwise, the heat generated by welding will affect the performance of the resilient seat.

The edge of the welding flange must be smoothed with a lathe to avoid damaging the valve seat. Flange surfaces must be completely free of damage and no deformation. In order to avoid the leakage of the valve and the flange connector, you should clean all dirt dust and foreign matter.

There is no need of gasket, when you install the FP10 butterfly valve. Clean the flange and the pipe inside to completely remove the splashes and other foreign matter of welding. When the valve is installed between the pipe, accurate alignment of the center of the pipe is essential for the trouble-free operation. The imprecise center point show in Figure 1 must be avoided.

When you install the valve, the bolts under the pipe should be located at the same and you should adjust the distance between the flange until the flange is about 6-10 mm apart from the pipe. Remember that the valve can only be opened from the closed position to the 10° location.

Insert the two bolts into the lower side of the valve and then carefully install it so that the flange surface does not damage the resilient seat (see Figure 2)

The other two bolts are then placed in the guide bar above the valve to ensure accurate center positioning between the pipe and the valve.

Open the valve three times to check if there is any obstruction between the valve disc and the flange.

Remove the anchor bolt and place all bolts around the body for alternating diagonal tightening (see Figure 3 Figure 4) until the flange touches the valve body. Refer to the table below for recommended torque values. The actuator is provided with a support to avoid distortion of the valve neck and to reduce friction between the valve and the pipe.

Do not trample on the valve neck or the valve hand wheel.

Do not reverse the installation of DN350 or larger valves.

Do not install the butterfly valve directly on the check valve or pump, which may cause damage when contacting the valve plate.

Do not install the valve on the downstream side of the elbow or tapered tube, or calibrate the valve as the flow rate changes. In this case, it is recommended that the valve be installed beyond 10 times times the nominal diameter of the valve.

The installation of the valve requires consideration of which valve plate will withstand changes in flow velocity and pressure during the conveying of the liquid. See illustrations. (Figure 5, Figure 6, Figure 7)

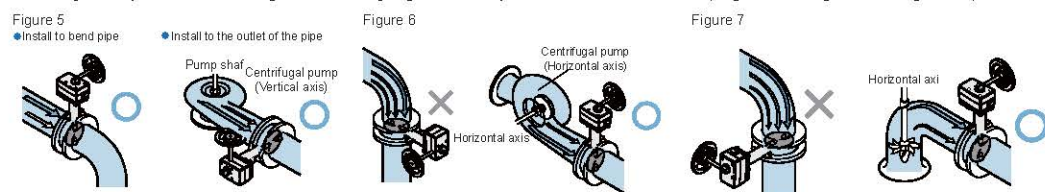

Warning

Do not remove the valve neck when the valve was pressurized in case the stem overflows. Also does not disassemble the valve actuator, to prevent the valve plate rotation, which would cause valve failure.

🔧 Precautions for installation and disassembly of valves

1. Attention of Valve Installation

Before the valve is installed, you should confirm that the valve conforms to the design requirements and the relevant standards. When handling and installing valves, beware of scratches. Before installing the valve, the inside of the pipeline should be cleaned and also should remove impurities such as iron filings to prevent the valve from sealing. In addition, the installation of the valve should be closed state.

Hoisting valve operation. The valve shall be properly lifted in the specified hoisting position, and the valve may not be lifted or towed only in the case of local force. In the installation of the valve, to confirm the flow of media, installation and handwheel position to meet the requirements.

2. Installation of Flange connection Valve

The flange surface of valve and piping should be free of damage, scratches and so on, and keep clean. In particular, the use of metal washers (oval or octagonal section), the flange of the groove and washers should be matched, to be coated with Red Lead for the study, to ensure that the seal in good condition.

The verticality of the flange surface of the piping and the center line of the piping and the error of the flange bolt hole shall be within the allowable value range. The valve and the piping center line should be made consistent before installation.

When connecting two flanges, the flange sealing surface and the gasket should be uniformly pressed, which ensures that the flange is connected by the same bolt stress.

When fastening bolts, you Fastening the Bolts and helical, in order to prevent from loosening caused by shake, and should use gasket. In order to avoid the adhesion between threads during high temperature, the thread part should be coated with anti-sticking agent(molybdenum disulfide).

3. Removal Notice of Valve

Precautions for general demolition should be subject to installation considerations. However, before disassembly, it should be confirmed that there is no pressure inside the pipe or valve, or replace the medium with inert gas.

Disassembly of flanged connecting valves: Bolts should be removed by wrench. When removing the profiled gasket, the straddle mark should be punched in the gasket and piping flange and the valve flanges. In order to protect the sealing surface of the valve flange, according to the situation, you can remove the valve by removing the flange of the two sides first.

4. Others

- The valve should be positioned before installed. The piping should be natural, and it cannot be wrenched when the position is wrong. The position is not hard to bend, lest leave prestress;
- The cryogenic valve should be in the cold state before the positioning (such as in liquid nitrogen) to do the opening and closing test, requiring flexible no jam phenomenon;
- Liquid valve should be configured into the valve stem and horizontal 10° tilt angle, to avoid liquid flow along the stem outflow, cold loss increase; The main point is to avoid the liquid to touch the sealing surface, so that it is chilled and lose the sealing effect, resulting in leakage;
- Large specifications of the pneumatic control valve should be installed, in order to avoid due to the larger valve core and biased side, increase the spool and bushing between the mechanical wear, causing leakage;
- When tightening screws, the valve should be in a micro-open state, so as not to press the top cover of bad valve;
- All valves in place, should be once again open and close, flexible without card phenomenon for qualified;
- It is forbidden to climb the stem as scaffold when installing;
- 200 °C above the high temperature valve, because the installation is at room temperature, but after the normal use, the temperature rises, the bolt heats expands, the gap enlarges, therefore must tighten again, is called "The Hot Tight", the operator should pay attention to this work, otherwise the leakage will be apt to occur.
- When the weather is cold, the water valve should be closed for a long time. After the steam valve is stopped, the condensation water should also be excluded. The bottom of the valve is like a wire plug, it can be opened drainage.



Ball Valve Installation

Do not remove the valve neck when the valve is pressurized in case the stem overflows.

Also do not disassemble the valve actuator, to prevent the valve plate rotation, causing valve failure.

I. The Installation of Thread Ball Valve

Check if the pipe can be screwed before sealing the tape.

Place the correct seals on both ends of the pipe and use PTFE ribbons to observe the direction of the screws and not to use seals that are not suitable for your industry.

Rotate the pipe through the threaded interface into the threaded interface at both ends of the valve. Check the tightness of all connections.

II. The Installation of Welded Ball Valve

Before soldering, you must disassemble the ball valve to prevent damage to the seal ring in the center part of the ball valve.

1. remove the ball valve Center part:

Cross loosen the nut and remove the screw on the body.

Remove the center part of the ball valve. Note that the seals and spheres in the center part of the ball valve should not be omitted. Put the parts carefully together. You can mark these components and assemble them quickly in future installations.

2. Welding ends

The center part of the ball valve must be positioned in the center part of the ball valve distance. The valve body and piping must be welded to comply with the relevant standards.

The safety of welding is required according to the position and orientation of the welding point.

If you can, notify your company's Foreman/Safety Engineer/engineering manager and the fire brigade of your factory at work.

To comply with the relevant regulations of the country and the accident prevention policy when welding.

3. after the end of the welding ball Valve Center part of the installation

Before installing the center part, it is necessary to cool the weld part.

Insert the center part between the ends of the connection and insert the correct nut between the ends. Check that no contaminated seals and spheres are in the correct position.

Insert the screws on both ends of the connection, tighten the nuts, and pay attention to the optimum torque of the screws. Check the performance of the ball valve.

Check the tightness of all connections.

III. The Installation of Flange Ball Valve

In the following description, we assume you have already cooled the flange piece that is soldered to the pipe.

Insert the flange seal between the ball valve and the flange piece.

Align the holes of the ball valve and the flange piece with the appropriate screws.

Screw the appropriate nut on the screws, tighten the nut in the diagonal way, and pay attention to the maximum torque of the screw.

Check the tightness of all connections.

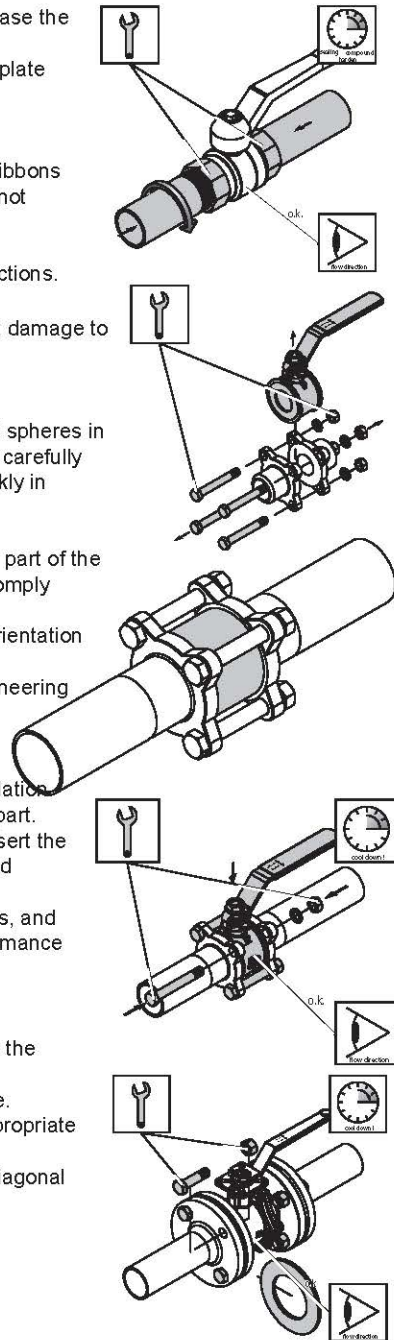

Precautions for installation and removal of valves

I. Precautions for valve installation

Before the valve is installed, confirm that the valve conforms to the design requirements and the relevant standards. When handling and installing valves, beware of scratches.

Before installing the valve, the inside of the pipeline should be cleaned to remove impurities such as iron filings to prevent the valve from sealing. In addition, the installation of the valve should be closed state.

Hoisting valve operation. The valve shall be properly lifted in the specified hoisting position, and the valve may not be lifted or towed only in the case of local force. In the installation of the valve, to confirm the flow of media, installation and handwheel position to meet the requirements.

II. Flange connection Valve Installation

The flange surface of valve and piping should be free of damage, scratches and so on, and keep clean. In particular, the use of metal washers (oval or octagonal section), the flange of the groove and washers should be matched, to be coated with Red Lead for the study, to ensure that the seal in good condition.

The verticality of the flange surface of the piping and the center line of the piping and the error of the flange bolt hole shall be within the allowable value range. The valve and the piping center line should be made consistent before installation.

When connecting two flanges, the flange sealing surface and the gasket should be uniformly pressed, which ensures that the flange is connected by the same bolt stress.

In fastening bolts, the use of matching with the nut wrench, when using oil pressure, pneumatic tools for fastening, pay attention to do not exceed the specified torque. The fastening of the flange should be avoided by force unevenness, and should be tightened in the order of symmetry and intersection. After the flange is installed, make sure all the bolts and nuts are solidly uniform.

The material of bolts and nuts must conform to the requirements. After fastening, the bolt head should be exposed two pitch in the nut.

Bolts and helical fastening, to prevent vibration caused by loosening, to use washers. In order to avoid the adhesion between threads during high temperature, the thread part should be coated with a viscosity inhibitor (molybdenum disulfide).

III. Precautions for Valve Disassembly

Precautions for general demolition should be subject to installation considerations. However, before disassembly, it should be confirmed that there is no pressure inside the pipe or valve, or replace the medium with inert gas.

Disassembly of flanged connecting valves: Bolts should be removed by wrench in principle. When removing the profiled gasket, the straddle mark should be punched in the gasket and piping flange and the valve flanges. In order to protect the sealing surface of the valve flange, according to the situation, you can remove the valve by removing the flange of the two sides first.

IV. Others

1. The valve should be positioned before the pipe is installed. The piping should be natural, the position is not hard to bend, lest leave prestress;
2. The cryogenic valve should be in the cold state before the positioning (such as in liquid nitrogen) to do the opening and closing test, requiring flexible no jam phenomenon;
3. liquid valve should be configured into the valve stem and horizontal 10° tilt angle, to avoid liquid flow along the stem outflow, cold loss increase; The main point is to avoid the liquid to touch the sealing surface, so that it is chilled and lose the sealing effect, resulting in leakage;
4. large specifications of the pneumatic control valve should be installed, in order to avoid due to the larger valve core and biased side, increase the spool and bushing between the mechanical wear, causing leakage;
5. When tightening screws, the valve should be in a micro-open state, so as not to press the top cover of bad valve;
6. All valves in place, should be once again open and close, flexible without card phenomenon for qualified;
7. It is forbidden to climb the stem as scaffold when installing;
8. 200 °C above the high temperature valve, because the installation is at room temperature, but after the normal use, the temperature rises, the bolt heats expands, the gap enlarges, therefore must tighten again, is called "The Hot Tight", the operator should pay attention to this work, otherwise the leakage will be apt to occur.
9. When the weather is cold, the water valve should be closed for a long time. After the steam valve is stopped, the condensation water should also be excluded. The bottom of the valve is like a wire plug, it can be opened drainage.
10. Non-metallic valves, some hard brittle, some low strength, operation, opening and closing force can not be too large, especially can not make arrayed. Also pay attention to avoid object bump.
11. when the new valve is used, the packing should not be pressed too tightly to avoid leakage, lest the stem be pressed too much to speed up wear and tear.

Operation

1. Valve operation notes

A competent valve operator should be in accordance with the training program received comprehensive training, technical internship qualified and able to play a good technical ability.

For a new operator, it is necessary to ensure adequate training time. Prior to the attainment of independent induction, should be skilled operators with the operation.

Please develop a standard system for valve operation.

For unconventional operations, the inspection operation plan should be compiled.

Sometimes it is done according to the instructions of the superior, and the instructions must be repeated to confirm the correctness. The specified valve is also confirmed when the operation is started.

2. Manual valve operation

The operation of the valve should often be contacted with the instrument room, the operation must be reported.

The valve should be operated gently to prevent noise, vibration and leakage.

In case of emergency, the operation should be especially cautious.

In the vicinity of the operation of the station with Flowmeter, thermometer, pressure gauges and other instruments, should pay attention to the instrument

Check the valve opening and closing signs and the degree of opening and closing (full, closed) whether there is a mistake.

3. Automatic valve operation

After mastering the display characteristic of the instrument to the operation quantity, the change quantity, the time lag and so on, can operate the automatic valve.

In the event of an emergency, the manual operation shall be in accordance with the relevant standards.

Regularly check and determine the operation of the gas source, power and other facilities no abnormal phenomenon.

In the operation of automatic valve, it is necessary to take into account the lag error of the valve in order to operate accurately.

At the beginning of operation and in the course of operation, the instrument to adjust, so that the correct action to ensure the reliability of the instrument.

Read the Manual of the valve factory carefully and fully understand the content.

Maintenance and Repair

1. Direction and position

The location of valve installation, must be easy to operate, even if the installation of temporary difficulties, but also for the long-term work of operators. The best valve handwheel with chest Chinzi (generally 1.2 meters from the operating floor), so that the opening and closing valve comparison Jingxiang. Floor valve handwheel to face up, do not tilt to avoid awkward operation. Rely on the wall machine valves, but also to leave the operator standing room. To avoid the operation, especially acid-base, toxic media, etc., otherwise it is very unsafe.

2. Construction work

Installation and construction must be careful not to impact the production of brittle materials valve.

Before installation, the valve should be checked, check the specification model, identify any damage, especially for the stem. Still need to rotate a few, see whether skew, because the transport process, the most easily hit the slanting valve stem. Also remove the debris in the valve.

When the valve is lifted, the rope should not be tied to the handwheel or stem to prevent damage to the parts and should be fastened to the flange.

For valves connected to the pipeline, be sure to clean. Use compressed air to blow iron oxide crumbs, mud sand, solder slag and other sundries. These sundries, not only easy to scratch the sealing surface of the valve, in which large particles of debris (such as solder slag), but also can block dead small valve, so that its failure.

Install the screw valve, should be sealed packing (line hemp plus lead oil or PTFE raw material belt), wrapped in the pipe thread, do not get into the valve, lest the valve memory product, affecting the circulation of media.

When installing flange valves, pay attention to symmetrical and evenly tighten the bolts. The valve flange and the pipe flange must be parallel, the clearance is reasonable, lest the valve produces the excessive pressure, even cracks. For brittle materials and the strength of the valve is not high, especially attention. The valve must be welded with the pipe, should be spot welding, and then closed fully open, and then weld dead.

3. Protection facilities

Some valves also need external protection, which is heat preservation and cooling. The insulation layer is sometimes accompanied by a hot steam pipeline. What kind of valve should be insulated or cold, according to the production requirements. Principle, where the medium of the valve to reduce the temperature too much, will affect the production efficiency or freezing the valve, it needs to heat, or even heat, where the valve bare, adverse to production or caused by frost and other undesirable phenomena, you need to keep cold. Insulation materials have asbestos, slag cotton, glass wool, perlite, diatomite, vermiculite, etc., cold-keeping materials have cork, perlite, foam, plastic and so on. Long-term use of water, steam valves must be drained.

4. Valve Maintenance

Valve in operation, all kinds of valve should be complete and intact. The bolts on the flange and the bracket are indispensable, the thread should be intact, and the loosening phenomenon is not allowed. The fastening nut on the handwheel, if found loose should be tightened in time, lest wear connection place or lose Handwheel and nameplate. If the handwheel is lost, it is not allowed to be replaced with a live wrench and should be matched in time. Padding gland does not allow skew or no pretension clearance. For the easy to be affected by rain and snow, dust, sand and other pollutants in the environment of the valve, the valve stem to install protective cover. The ruler on the valve should be kept intact, accurate and clear. Valve seals, caps, pneumatic accessories should be complete intact. The insulation jacket should be free of dents and cracks. It is not permissible to knock, stand or support the valve in operation, especially nonmetal valves and cast iron valves.

The Daily maintenance work of the electric equipment, usually a lot of monthly and once. Maintenance of the contents are: the appearance of clean, no dust stains: The device does not suffer, water, oil contamination. The electric device seals well, each seal surface, the point should be complete firm, tight, without divulging. Electric device should be lubricated well, on time according to the provisions of refueling, stem nut plus grease. The electrical part should be intact, should not damp and dust erosion; if damp, need to use 500V trillion-euro meter to measure all the load flow part and the insulation resistance between the shell, its value is not less than 0.38 trillion ohms, otherwise the relevant parts should do dry treatment. Automatic switch and thermal relay should not be deducted, the LED display is correct, there is no phase, short circuit, circuit breaker fault. The working state of the electric device is normal and flexible.

The Daily maintenance work of the pneumatic device, in general, a lot of monthly and once, maintenance of the main contents are: the appearance of clean, no dust stains: device does not suffer, water, oil contamination. Pneumatic device hungry seal good, each seal surface, point should be intact and strong, strict non-destructive. The manual operation mechanism should be lubricated well and the opening and closing is flexible. Cylinder inlet and outlet gas connector not permitted have damage; each part of the cylinder and air piping system shall be carefully inspected and shall not affect the use of the leakage of performance. The pipe is not allowed to have sunken, the signal device should be in good condition, the signal indicator light should be intact, whether is the pneumatic signal device or the electric signal connection thread should be intact, must not have the divulging. The valve on the pneumatic device should be intact, no leakage, open flexible, airflow unobstructed. The whole pneumatic device should be in normal working condition and flexible in opening and closing.

Fault analysis and elimination

Manual Valve

Fault phenomenon	Reason	Troubleshooting Methods
External leakage	The stuffing box is not pressed good	Tighten the stuffing box or increase the number of fillings
	The metal seal ring is not compacted or damaged.	Balance and fasten flange nut or replacing metal seal ring
Internal leakage	The valve cannot be closed	Adjust the itinerary of actuators
	Insufficient torque for actuator	To replace or enlarge the actuator torque
	Valve seat and core are washed	Replace valve seat, valve core,
Stick	Actuator failure	Locate the cause ,repair or change actuator
	Foreign body inside valve	Disassemble valve and Check, clean foreign body, and replace damaged parts
	Flange nut fastening unbalance	Adjusting Flange Nut

Pneumatic Valve

Fault phenomenon	Reason	Troubleshooting Methods
No specified supply pressure in cylinder	Air compressor air pipeline valve, solenoid valve, are abnormal	Repair it. Ensure the air pressure is 6.Kg for DA Pneumatic actuator, 6.5KG for SR pneumatic actuator.
Specified pressure supply in cylinder but the actuator do not working.	The valve is jammed with impurities inside	Disassemble valve to replace valve seat
	The actuator doesn't work	Disassemble the cylinder to check if the internal seals are damaged and replace the broken
	Check the valve individually to see if the valve torque is greater than the working torque, or that there is a foreign body stuck	increase the working pressure of the cylinder.Open the valve , clean, repair, or replace it.
	Valve working torque less than rated torque Valve working torque less than rated torque Valve working torque less than rated torque	Readjust the actuator to match the valve

Trouble analysis and elimination

Trouble analysis and elimination of electric valve

I.Manual Operation

Shut off the electricity before the manual operation.

In manual operation, the power supply must be cut off first.Take off the rubber cap of the deceleration cover,Insert the accompanying handle into the hexagonal hole.Rotate the manual handle in clockwise direction to reduce the opening.

Note: When it is full open or closed, the limit switch to create the movement of the half circle, will encounter the mechanical block, excessive rotation, will lead to other parts of the damage, so to avoid excessive force.

II.Electric Operation

Before electric operation, you should use manual operation method to check whether the opening and valve angle (full open or closed) are consistent.Whether the wiring is correct.You must use the limited switch, then confirm the On-off action;

After confirming the above condition, start the electric operation.

Note:

1.check the wiring diagram, power supply, input and output signal,and confirm whether they are normal.

2.try not to change the internal wiring.

3.if the power supply is 3 phase, you should check the direction of rotation.

4. Make the actuator half open/closeManually , power up and enter the signal.5. 5.If the actuator is running to the open position, the wiring is correct.

If it moves in the opposite direction, you must exchange two of the three power cords

III. Maintenance

Refueling: Because of the long service life, good pressure resistance of special molybdenum grease, so there is no need to refuel;

regular operation: When the valve is rarely running, you can drive the machine regularly to check for abnormalities.

Instruction of Electric Actuators

For Your Safety

For better and safety use for a long period, please observe this warning and caution carefully

Warning

This product is not of explosion-proof. Do not use it in the environment with flammable gas (gasoline etc.) or corrosive gas.

Do not dismantle the actuator from the valve during power operation.

Do not do wiring work when power is being supplied.

Working Caution

Do not drop the product or give a shock to the product, for it may cause defects to the product.

Please do not connect in the rain or water splash in the environment.

General

This serial product is a high performance quarter-turn rotary type electric valve actuator for on/off and intermediate position service.

Feature

- 1.Compact and light
- 2.Manual operation by crank handle available
- 3.Thermal protection from motor burn-out
- 4.IP67 Water proof to IP 67
- 5.ISO5211 mounting

Wiring Diagram

Note: This wiring diagram is only for reference. Please follow the diagram adhere on the product.

Normal On-off Type

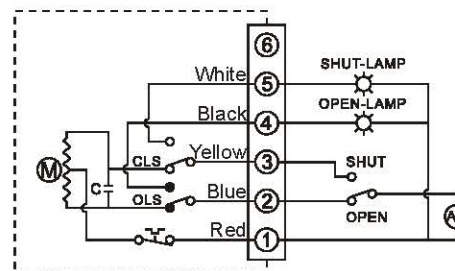

Passive Switching Signal

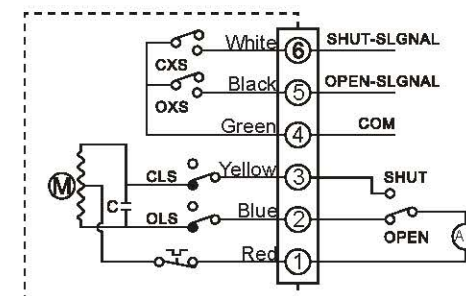

Intelligent Adjustment Type

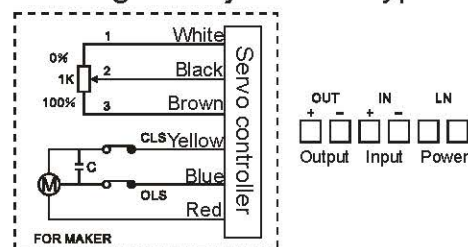

Dc Switch Type

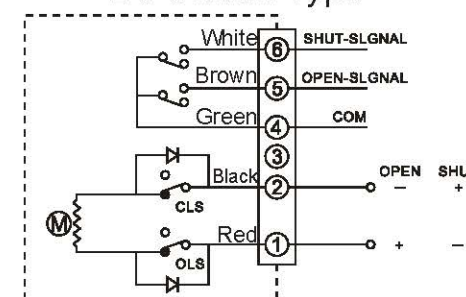

Three-phase On-off Type

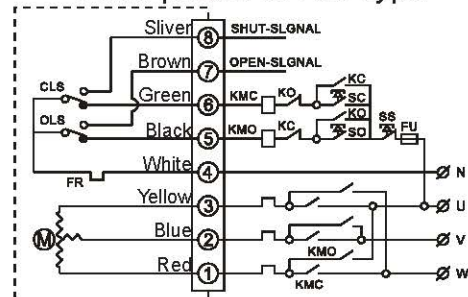

Three Phase Passive Contact Type

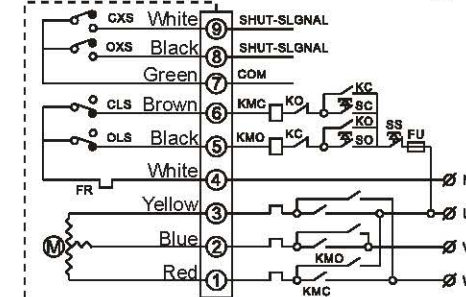

Performance Parameter

Model	Max. Torque (N.M)	90°(S) Running Time (s)	Rotate Angle	(W) motor	(Cur) 220V (A)50HZ	(Kg) Weight
FLOWX-005	50	20	0~360°	10	0.16	2
FLOWX-010	100	30	0~360°	25	0.35	3
FLOWX-020	200	30	0~90°	40	0.37	8
FLOWX-040	400	30	0~90°	90	0.57	8.5
FLOWX-060	600	45	0~90°	90	0.6	9
FLOWX-100	1000	30	0~90°	120	0.94	17
FLOWX-160	1600	48	0~90°	140	0.96	17
FLOWX-250	2500	75	0~90°	140	0.98	18

Common technical data

Power supply	110V AC, 220V AC, 380V AC, 24V DC
Motor	Squirrel-cage Asynchronous type
Waterproof	IP67
Conduit	M20*1.5
Ambient Temp.	-20°C - +60°C
Option	Heater
External coating	Epoxy polyester

Installation

1. Caution of installation

This product is not of explosion-proof type. Do not install in hazardous place.

Need a protective cover if it is installed in a water or material splashing area or direct sunlight area.

Please reserve a space for manual maintenance.

2. Ambient and Fluid Temperature

2.1 Ambient temperature

Ambient temp: -30°C~60°C

For use in minus temp, in-fit space heater is available at option

2.2 Fluid Temperature

If the actuator is applied to a high temp fluid application, the unit may overheat by transmission of heat.

Standard bracket: fluid temp max. 65°C

Radiation type bracket: fluid temp over 65°C

3. Cable Requirement

Using a cable of Ø9~11 for the standard connector. If a customer connector is used, select a proper diameter to prevent water ingress to the unit.

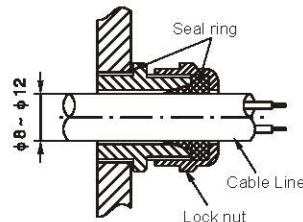

4. Power supply

Power supply according to the actuator type.

The power need meet the following requirement:

AC380V±10% 50/60Hz	AC220V±10% 50/60Hz	AC110V±10% 50/60Hz	DC24V±5%
--------------------	--------------------	--------------------	----------

5. The option of fused disconnect switch :

Model	Voltage			
	DC24V	AC110V	AC220V	AC380V
FLOWX-005	5A	3A	2A	2A
FLOWX-010	7A	5A	3A	2A
FLOWX-020、40、60	15A	7A	5A	3A
FLOWX-100、160、200	/	10A	7A	5A

6. Assembly with the valve

6.1 Turn valve smoothly by hand to confirm the condition, then position it at full close.

6.2 Bolt a bracket at valve as needed.

6.3 Tentatively mount actuator on the bracket with loose bolt.

6.4 Position the actuator at close, joint the output shaft and the valve stem with coupling.

6.5 Screw up the bolts.

6.6 Check with attached crank handle if the valve turns smoothly without eccentricity.

7. Adjustment

7.1 Adjustment of limit switches. (Fig 2)

7.2 Fully close the valve, loosen and turn the lower limit dog (Gray) And confirm that the switch is effective.

Then tighten the setting nut.

7.3 For open side, fully open the valve, turn the upper limit dog. (yellow)

7.4 Tighten the setting nut, adjustment of the valve position indicator is completed.

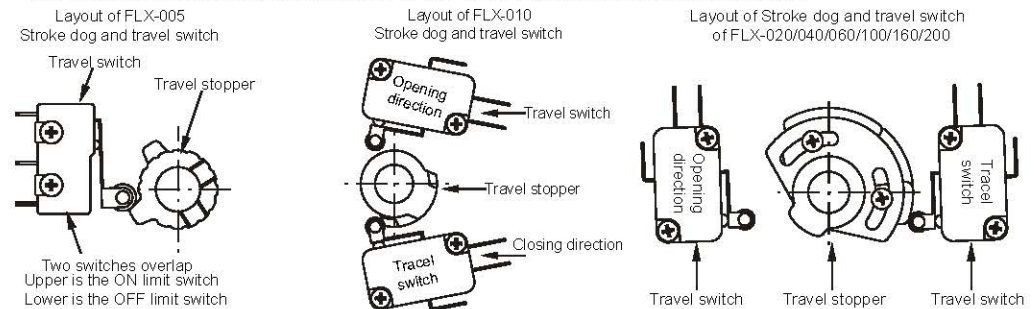

7.5 Close the valve fully by manual handle.

7.6 Loosen, return the stopper by 1/2 with the adjust bolt. Screw up the locknut.

7.7 Adjust open side in same manner.

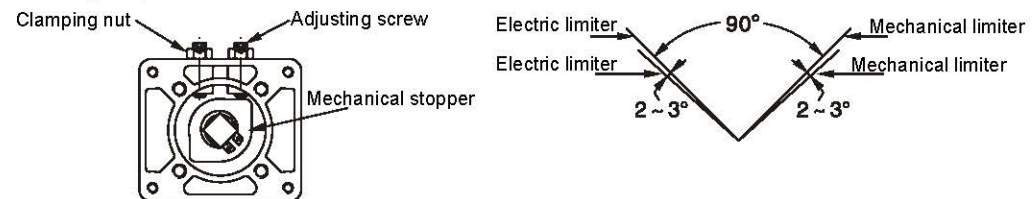

8. Trialrunning

8.1 Manual operation

Be sure power off before making manual operation.

Insert the manual handle into the hexagonal socket underneath the rubber cap, turn to close and open.

Turn the handle clockwise for close, counter clockwise for open.

When making manual override, be sure to check valve position with position indicator. The limit switches become effective at close/open position.

The stops are at 1/2 turn beyond those points. Do not apply excessive force to the handle, for it might damage the unit.

8.2 Power operation

Before making power operation, Confirm the indication on the position meter and the valve opening are matching.

Confirm that wiring is correct, also the unit operates in correct direction with external switches.

Then start power operation.

9. Maintenance

9.1 Lubrication

As major parts has lubricated with long life disulfide molybdenum grease before shipment, re-lubricate is not required.

9.2 periodically operation

When the valve works infrequently, Suggest to run the actuator regularly to check validity.

Instruction of Pneumatic Actuators

For Your Safety

For better and safety use for a long period, please observe this warning and caution carefully

Warning

Before removing any components of the actuators, ensure that all pneumatic are disconnected.

The actuator should only be used within pressure/temperature limits.

Do not disassemble individual spring cartridge.

Working Caution

For optimal operation, actuators should be run with a supply of clean, lubricated air.

The max. supply pressure is 8 Bar

The operation temperature of standard product is from -20°C to $+80^{\circ}\text{C}$, low temperature kits (-40°C to 80°C) and high temperature kits (-20°C to 150°C) are available.

Operation

The standard rotation is clockwise to close.

Double Acting Actuators (Standard Rotation)

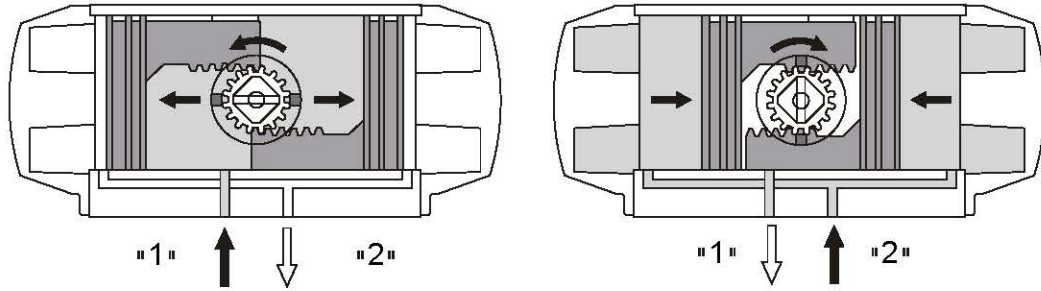

Air to port 2 forces the piston apart and toward the end position, which causes the actuator to turn CCW.

Air to port 1 causes the actuator to turn CW.

Spring Return Actuators (Standard Rotation)

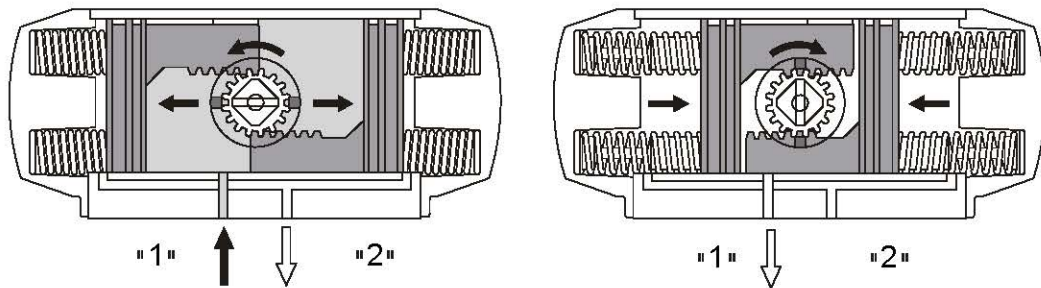

Air to port 2 forces the piston apart and toward the End position, Compressing the springs with exhaust air existing at port 1, which causes the actuator to turn CCW.

Loss of air at port 2 allows the springs to force the piston to the centre position and causes the actuator to turn CW. This is the FAIL CLOSE operation.

Standard Actuators Disassembly

1. Loosen the end cap fasteners with a wrench (size varies depending on the model). On the spring return actuator, unscrew 4~5 turns on each fastener till the springs are decompressed.
2. Loosen the stop cap screws.
3. Turn the pinion shaft CCW until the pistons are released. Disengage the pistons.
4. Remove the pinion snap ring. And take away the thrust washer and external spacer ring.
5. Apply downward force gently to top of drive shaft until it is partially out of the bottom of body. Remove the cam and internal spacer ring. Then push the pinion completely out of the bottom of body.
6. All replacement parts may now be put in. All wear parts are suggested to be replaced before reassembly.

Standard Actuators Reassembly

1. Check that all components are clean and free from damage. Apply the suitable grease to all o-rings and pinion and pistons.
2. Put the pinion back through the actuator partially, install the cam in the shown position, (Fig 1,) Install the internal spacer rings, insert the pinion into the body completely.
3. Install external spacer ring, then thrust wash and snap ring.
4. Rotate the pinion to the position shown in fig. 2 (top view), Press two pistons simultaneously, inside the body until the pistons are engaged. (The normal operation of actuators is Fail Closed , if you want to be Fail Open, rotates the rack 180o to create a reverse operation)
5. Screw in one travel stop assembly with locknut and seal until it comes into contact with the pinion. Rotate the pinion 90 degrees and screw in the other travel stop until it comes into contact with the pinion. The final adjustment is made when the actuator has been mounted the valve to suit individual requirements.
6. Install the correct number of springs for the desired torque. Balance the springs across the pistons for SR model.
7. Seal the end cap and bolt to the body.
8. Check the seal of the actuator by covering seal areas (pinion, end caps) with soapy water and using the pressure air to actuator to ensure that no bubbles are produced.

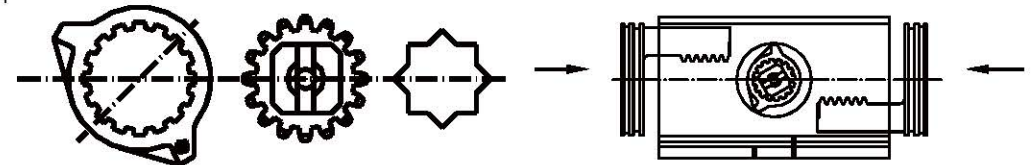

Fig 1

Fig 2

Pneumatic Double Acting Torque (NM)

Model	Air pressure(bar)							
	2.5	3	4	5	5.5	6	7	8
	Double-acting pneumatic actuator output torque(NM)							
FP-32DA	3.5	4.2	6	7.5	8	9	10	11.5
FP-52DA	8.3	10	13.3	16.6	18.3	19.9	23.3	26.6
FP-63DA	14.7	17.6	23.5	29.3	32	35.2	41	46.9
FP-75DA	29	35	46.5	58.2	64	70	82	93
FP-85DA	45.8	54.9	73.2	91.5	101	110	128	146
FP-100DA	66	79.8	106	133	146	160	186	213
FP-115DA	107	129	172	215	236	258	301	344
FP-125DA	138	166	222	277	305	332	388	443
FP-145DA	217	261	348	435	478	522	609	696
FP-160DA	284	340	454	567	624	681	794	908
FP-180DA	383	459	613	766	842	919	4172	1225
FP-200DA	532	638	851	1064	1170	1276	1489	1702
FP-240DA	1160	1392.5	1857	2321	2553	2785	3249	3713
FP-270DA	1550	1860	2480	3100	3410	3720	4341	4961

Actuator Air Consumption Chart (liter)

Model	32	52	63	75	85	100	115	125	140	160	180
DA	0.07	0.23	0.44	0.83	1.15	1.88	3.03	3.96	5.42	8.24	11.5
SR	-	0.1	0.18	0.35	0.53	0.82	1.31	1.7	2.4	3.5	4.58

Weight chart (kg)

Model	32	52	63	75	85	100	115	125	140	160	180
DA	0.5	1.1	1.6	2.9	4.2	5.6	9.1	10	15	21.3	26.8
SR	-	1.4	1.7	3.2	4.7	6.4	10.8	13.5	20.5	24.5	32

Working time (sec.)

Model	32	52	63	75	85	100	115	125	140	160	180
CW DA	0.1	0.2	0.3	0.4	0.5	0.6	0.8	1.1	1.4	1.7	2.3
CCW DA	0.1	0.2	0.3	0.3	0.4	0.5	0.7	1	1.2	1.5	2
CW SR	-	0.3	0.4	0.5	0.6	0.9	1	1.4	1.8	2.1	2.9
CCW SR	-	0.3	0.3	0.4	0.5	0.7	0.9	1.2	1.6	2	2.5

The standard operation time is for reference only. It is the data of unloaded valve at 5 Bar pressure. There may be significant difference in practical application

DA=Double-acting pneumatic actuator SR=Spring-acting pneumatic actuator

If you need a single action pneumatic actuator torque table please consult FLOWX Company

Other produces of our company

Multi-turn electric actuator

Explosion-proof electric actuator

FLX-210N limit switch box

Express open/closed electric actuator

Hyperslow electric actuator

BUTTERFLY VALVE

WORLD WIDE VALVE SUPPLIER AROUND YOU



• ITALY FLOWX VALVE S.R.L.

Tel: +39 06 5236 2443
E-mail: tjf@flowxvalve.com

• Shanghai Flowx Valve Co.,Ltd

Zip Code: 200245
Tel: 021 5415 0349
E-mail: sales@flowxvalve.com

• Beijing Branch

Zip Code: 100020
Tel: 182 2149 6018
E-mail: jianing.hou@flowxvalve.com

• Guangdong Branch

Tel: 0769 2208 2205
Fax: 0769 2332 3876
E-mail: yufeng.chen@flowxvalve.com

• Shandong Branch

Tel: 139 1732 1517
E-mail: chun.zhou@flowxvalve.com

• Henan Branch

Tel: 177 3720 1280
E-mail: udong.hou@flowxvalve.com

Technical Service Hotline: 021-58560269
After Sales Service Email: lei.ni@flowxvalve.com
www.flowxvalve.com



Company Website



Flowx Valve Online
Shops Wechat